

REVISION HISTORY				
REV.	DESCRIPTION	DATE	ECO	BY
05	CORRECTED TITLE BLOCK, WAS HYDRA POOLS.	6/14/2013	NONE	JBOSSERDET
06	UPDATED PART NUMBER	7/1/2013	NONE	KJULIAN

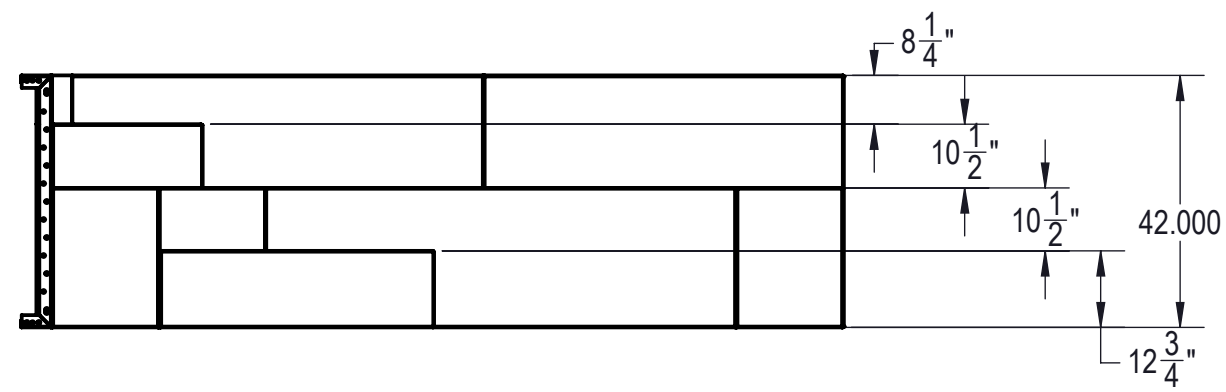
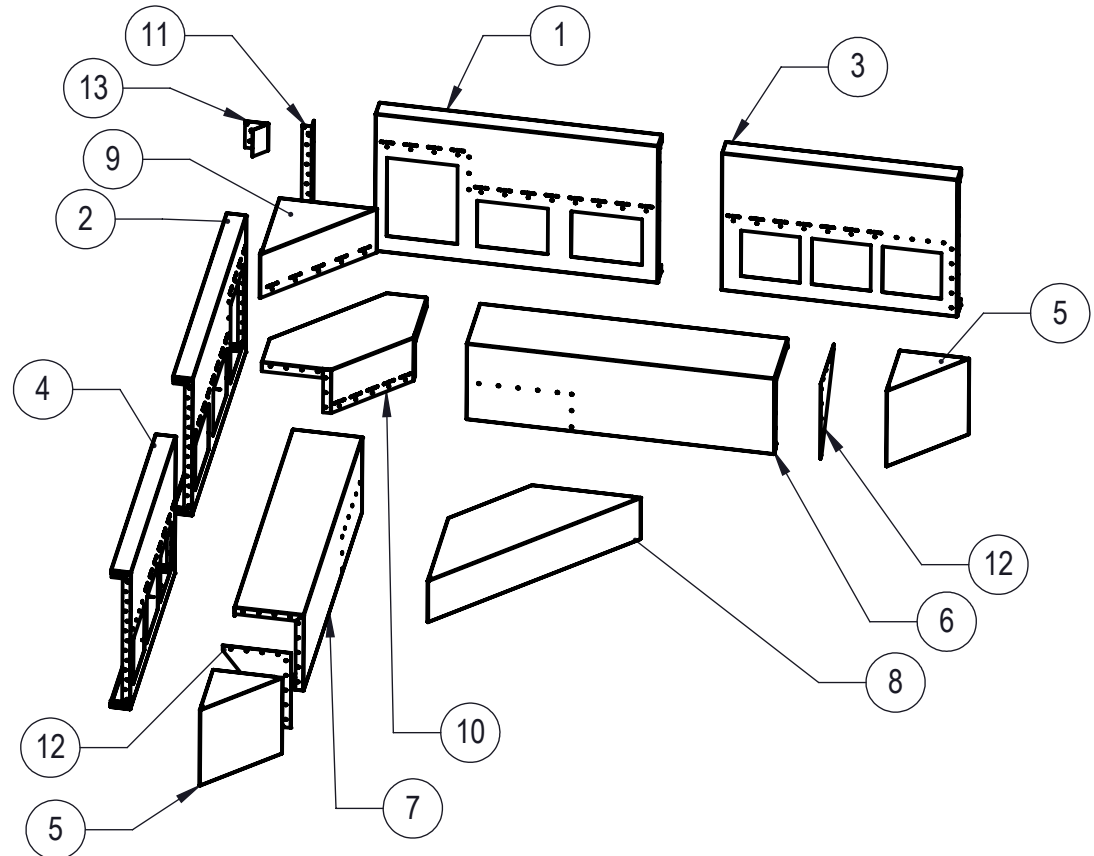
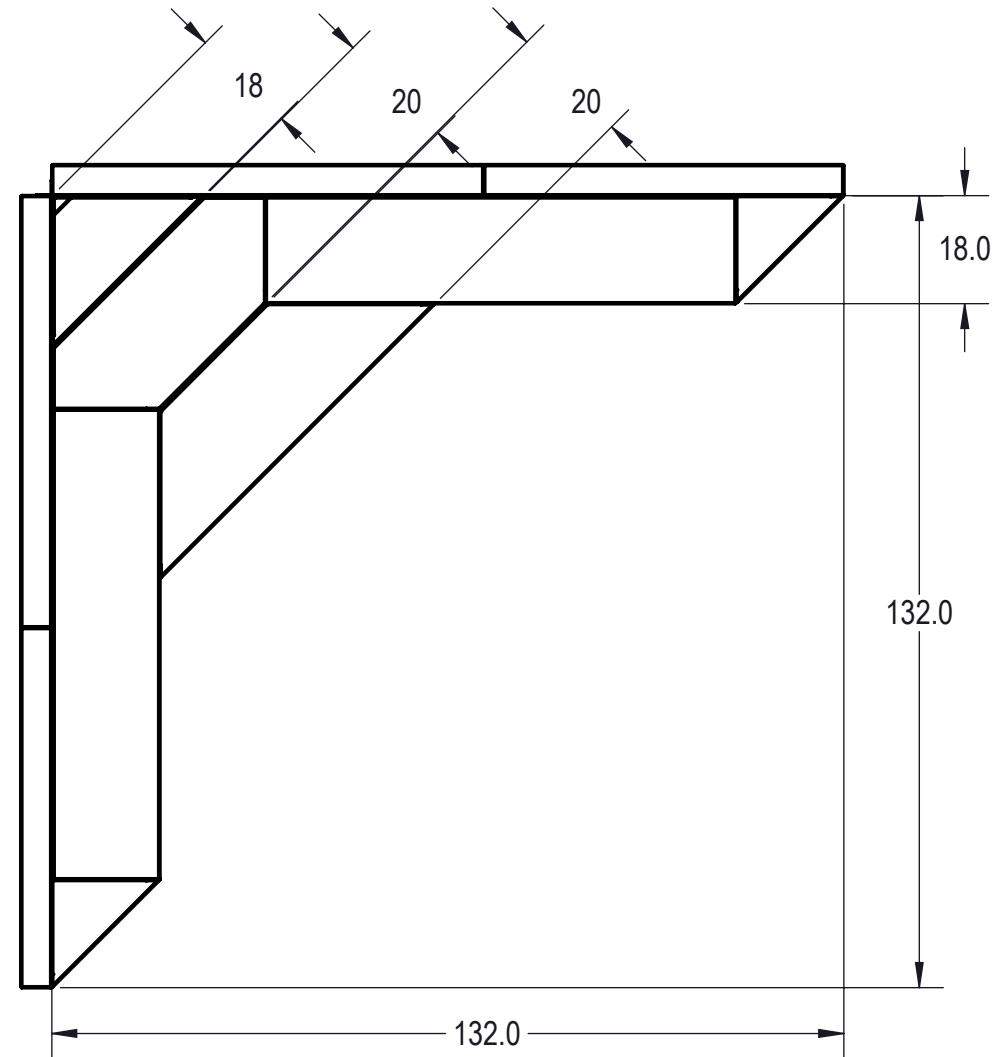

ITEM	FILE NAME	DESCRIPTION	CUSTOMER DRAWING #	VENDOR PART #	QTY.	VENDOR NAME	MATERIAL
1	00002281	PANEL, STEP, 6' LONG, RIGHT SIDE			1	HYDRA POOLS, IA	G-235, 14 GA
2	00002283	PANEL, STEP, 6' LONG, LEFT SIDE			1	HYDRA POOLS, IA	G-235, 14 GA
3	00002280	PANEL, STEP, 5' LONG, RIGHT SIDE			1	HYDRA POOLS, IA	G-235, 14 GA
4	00002282	PANEL, STEP, 5' LONG, LEFT SIDE			1	HYDRA POOLS, IA	G-235, 14 GA
5	00002285	STEP, END CAP, 45 DEGREE, RIGHT OR LEFT HAND			2	HYDRA POOLS, IA	G-235, 14 GA
6	00002284	STEP, BENCH, RIGHT SIDE			1	HYDRA POOLS, IA	G-235, 14 GA
7	00002329	STEP, BENCH, LEFT SIDE			1	HYDRA POOLS, IA	G-235, 14 GA
8	00002287	STEP, BOTTOM TREAD			1	HYDRA POOLS, IA	G-235, 14 GA
9	00002289	STEP, TOP TREAD			1	HYDRA POOLS, IA	G-235, 14 GA
10	00002288	STEP, CENTER TREAD			1	HYDRA POOLS, IA	G-235, 14 GA
11	00000051	CONNECTOR, CORNER, 2 1/2" X 1 1/2" X 90°	HPSD90C	HPSD90C	1	HYDRA POOLS, IA	G-235, 14 GA
12	00002328	STEP, BENCH, SEAT, SUPPORT			2	HYDRA POOLS, IA	G-235, 14 GA
13	00002627	STEP, INSERT, 6" RADIUS, 3 TREAD, CORNER STEP			1	SAMSON STEEL	G-235, 14 GA
14	00000305	HBOLT 0.3750-16x1-N			179	HYDRA POOLS	AISI 1020
15	00000306	HNUT 0.3750-16-D-N			179	HYDRA POOLS	Material <not specified>

ENGINEERING DRAWING NUMBER: 00002279	WEIGHT: 580.0 lbs	UNLESS OTHERWISE SPECIFIED DIMENSIONS ARE IN INCHES TOLERANCES DECIMALS: X ± 0.1 XX ± 0.01 XXX ± 0.005 XXXX ± 0.0005 ANGULAR: X ± 0.5 THIRD ANGLE PROJECTION	DESIGNED BY: LNELSON	CREATION DATE: 4/5/2013	SAMSON STEEL
	VOLUME: Inch ³		DETAILED BY: KJULIAN	DETAILED DATE: 10/5/2012	
	COLOR:		LAST REVISED BY: hyeng	LAST REVISED DATE: 7/1/2013	
	HEAT TREAT:		MATERIAL:	TITLE: STEP, 11 FT, CORNER, 3 TREAD, WITH BENCHES, LINER TRACK	
FINISH:				PART NUMBER: HSS11B3	SCALE: 1:32
TEXTURE:					SIZE: 1 OF 1