

PRIMO 56" FOOSBALL TABLE ASSEMBLY INSTRUCTIONS



**Please Do Not Hesitate to
Contact Our Consumer Hotline
at 800-759-0977
with Any Questions That May
Arise During Assembly or
Use of This Product!**

NG1035

THANK YOU!











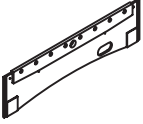
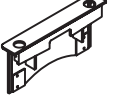
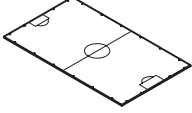

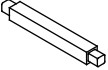

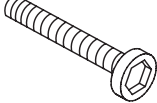
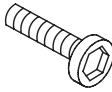

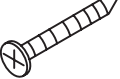
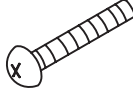
Thank you for purchasing this product.

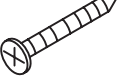
We work around the clock and around the globe to ensure that our products maintain the highest possible quality. However, in the rare case of issues during assembly or use of this product, please contact our Consumer Hotline at **800-759-0977** for immediate assistance before contacting your retailer.







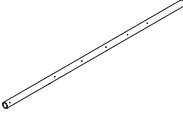

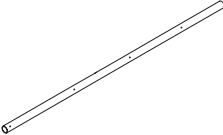
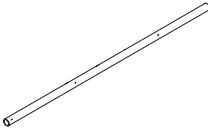

Please read the warranty information at the back of these assembly instructions for further details.

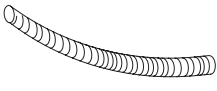
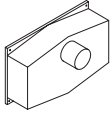
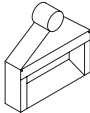
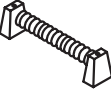
**IMPORTANT! PLEASE READ THESE ASSEMBLY INSTRUCTIONS
IN ENTIRETY BEFORE ASSEMBLING YOUR PRODUCT.**

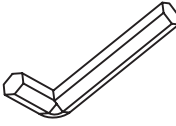
PARTS IDENTIFIER (NOT TO SCALE)

<p>#1</p>  <p>Side Panel 2 pieces</p>	<p>#2</p>  <p>End Panel 2 pieces</p>	<p>#3</p>  <p>Playing Field 1 piece</p>	<p>#4</p>  <p>Left Leg 2 pieces</p>	<p>#5</p>  <p>Right Leg 2 pieces</p>
<p>#6</p>  <p>Leg Panel 2 pieces</p>	<p>#7</p>  <p>Playfield Support Brace 2 pieces</p>	<p>#8</p>  <p>5/16" Flat Washer 16 pieces</p>	<p>#9</p>  <p>5/16"x35mm Bolt 16 pieces</p>	<p>#10</p>  <p>1/4"x60mm Bolt 8 pieces</p>
<p>#11</p>  <p>1/4" Flat Washer 8 pieces</p>	<p>#12</p>  <p>4X12mm Round Head Screw 28 pieces</p>	<p>#13</p>  <p>4x25mm Flat Head Screw 24 pieces</p>	<p>#14</p>  <p>1-1/8" Bolt 26 pieces</p>	<p>#15</p>  <p>Locknut 26 pieces</p>
<p>#16</p>  <p>4x12mm Flat Head Screw 2 pieces</p>	<p>#17</p>  <p>4x18mm Round Head Screw 4 pieces</p>	<p>#18</p>  <p>4X45mm Round Head Screw 4 pieces</p>	<p>#19</p>  <p>Rod Handle 8 pieces</p>	<p>#20</p>  <p>Rod Washer 16 pieces</p>
<p>#21</p>  <p>Rod Bumper 16 pieces</p>	<p>#22</p>  <p>Visit Player 11 pieces</p>	<p>#23</p>  <p>Home Player 11 pieces</p>	<p>#24</p>  <p>5 Player Rod 2 pieces</p>	

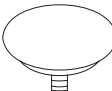
PARTS IDENTIFIER (NOT TO SCALE)

<p>#25</p>  <p>3 Player Rod 4 pieces</p>	<p>#26</p>  <p>2 Player Rod 2 pieces</p>	<p>#27</p>  <p>Ball Entry Cap 2 pieces</p>	<p>#28</p>  <p>Ball Runner 2 pieces</p>
<p>#29</p>  <p>Side Ball Catcher 2 pieces</p>	<p>#30</p>  <p>Ball Catcher 2 pieces</p>	<p>#31</p>  <p>Manual Scorer 2 pieces</p>	<p>#32</p>  <p>Silver Plastic Cup 4 pieces</p>
<p>#33</p>  <p>Allen Key 1 piece</p>	<p>#34</p>  <p>Soccer Ball 2 pieces</p>	<p>#35</p>  <p>Apron Corner 4 pieces</p>	<p>#36</p>  <p>Rod End cap 8 pieces</p>
<p>#37</p>  <p>Leg Leveler 4 pieces</p>	<p>#38</p>  <p>Stop Ring 4 pieces</p>	<p>#39</p>  <p>5/8" Bolt 8 pieces</p>	

Please see Parts List at end of manual for part number when ordering parts. For replacement parts please call 800-759-0977.

ASSEMBLY TIPS

1. Find a clean, level surface to begin the assembly of your game table. The table will be partially assembled upside down and then turned over onto its legs. This is a heavy game and turning it over will require at least two strong adults.
2. Remove all of the contents from box and verify that you have all of the parts shown on the Parts Identifier before you begin assembly. **Note: Some parts may be pre-installed or pre-assembled.**
3. Some figures or drawings may not look exactly like your product. Please read and understand the text before beginning each assembly step.
4. **When installing parts that have more than one screw or bolt, hand tighten all screws or bolts in place before finishing tightening with screwdriver or hex wrench.**
5. Electric screwdrivers may be helpful during assembly; however, please set a low torque and use extreme caution because screws may be stripped or overtightened if the electric screwdriver's torque is set too high.

WARNINGS!

READ AND FOLLOW ALL ASSEMBLY, OPERATION AND SAFETY INSTRUCTIONS CAREFULLY.

CHOKER HAZARD - THIS TABLE CONTAINS SMALL BALLS AND PARTS - NOT
SUITABLE FOR CHILDREN UNDER 3 YEARS OF AGE.

ASSEMBLY INSTRUCTIONS

1. Place PLAYFIELD #3, with field markings facing down, onto the ledge of the SIDE PANELS #1.
Note: The table is assembled upside down.

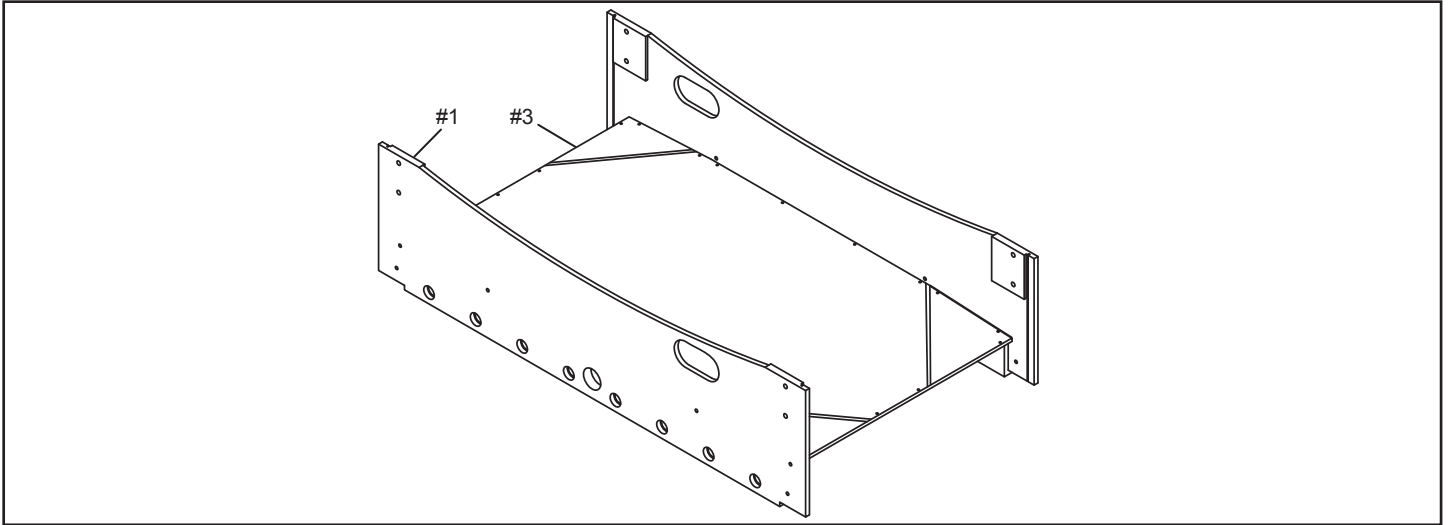

2. Attach one END PANEL #2 to each end of the table with 1/4" BOLT #10 and 1/4" FLAT WASHER #11.
Note: DO NOT over tighten bolts. In this step, loosely tighten just until sides touch.
3. Attach PLAYFIELD to table with 1" FLAT SCREWS #13 around inside edge using pre-drill holes. *Note: ALWAYS use pre-drilled holes. If not, permanent damage can be done to table. A flashlight can be helpful in aligning holes. It may be helpful to have a second person push on the opposite side, as you attach Playfield, in order to square up surface. Make sure End Panels fit snugly against Side Panels before screwing down Playfield.*
4. Insert the APRON CORNERS #35 onto the SIDE PANELS #1 and END PANELS #2 on the four corners.
Note: Make sure inside screw holes are positioned at top.
5. Tighten 1/4" BOLTS #10, loosely tightened in Step 2, on both sides.

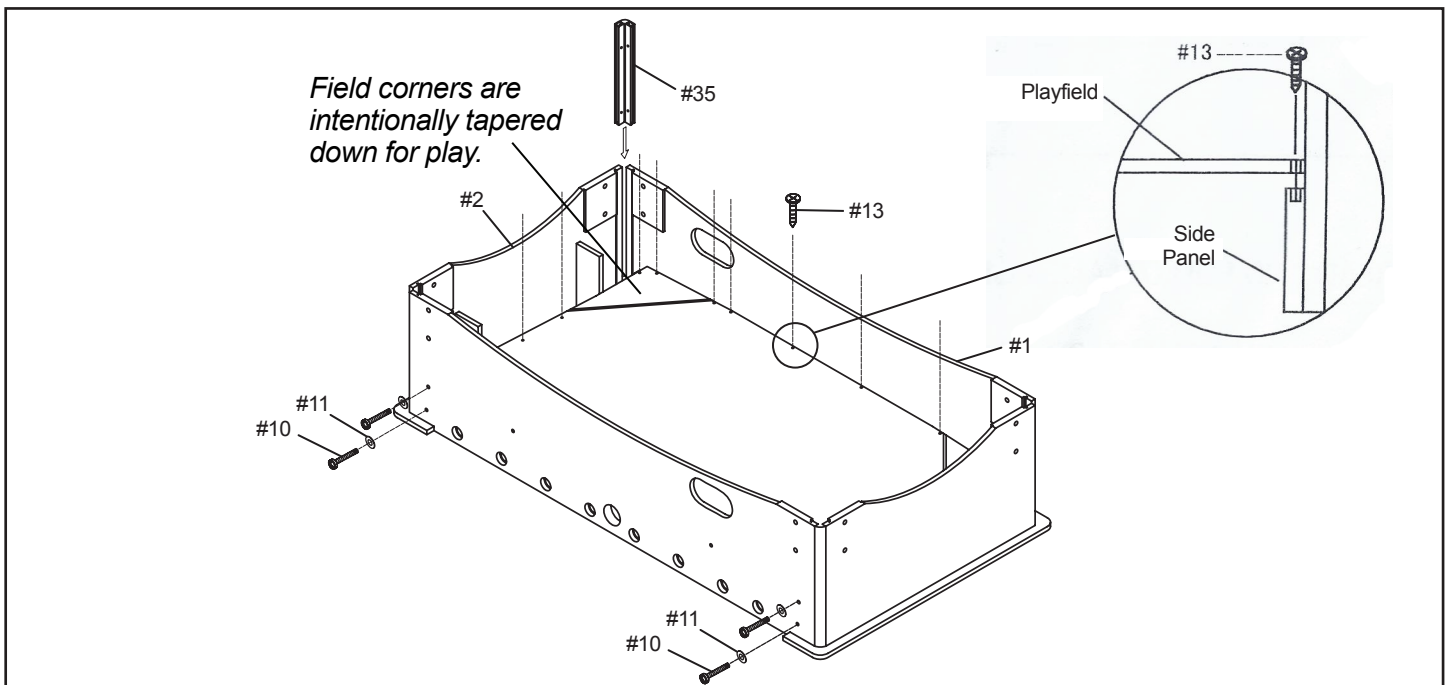

ASSEMBLY INSTRUCTIONS

5. Position each PLAYFIELD SUPPORT BRACE #7 between the SIDE PANELS as shown below. Attach the SUPPORT BRACE #7 with 1-3/4" SCREW #18. Attach the APRON CORNERS to each corner of the table with 1/2" SCREW #12.

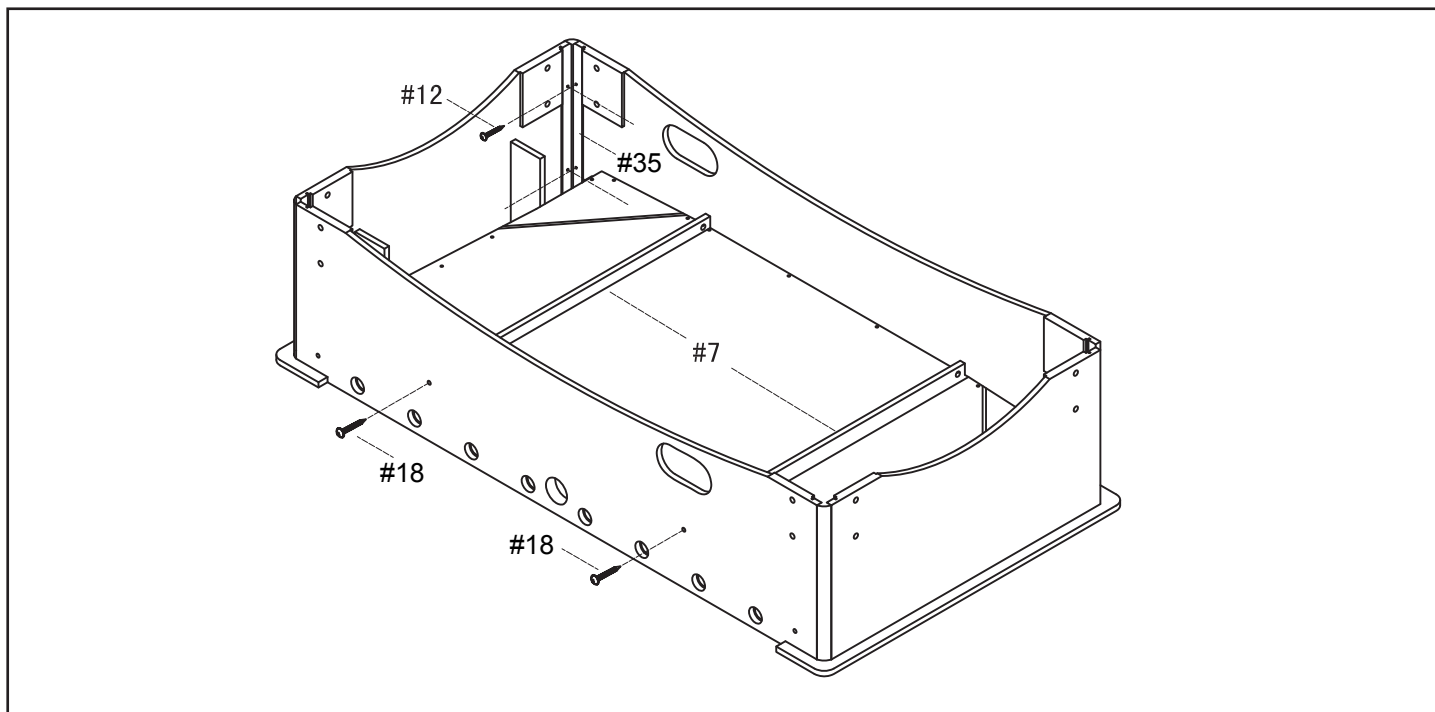

6. Attach the SIDE BALL CATCHER #29 to each of the SIDE PANELS with 1/2" SCREW #12. Attach the BALL CATCHER #30 to each of the END PANELS with 1/2" SCREW #12. Attach the BALL RUNNER #28 onto the SIDE BALL CATCHER and the BALL CATCHER openings as shown below.

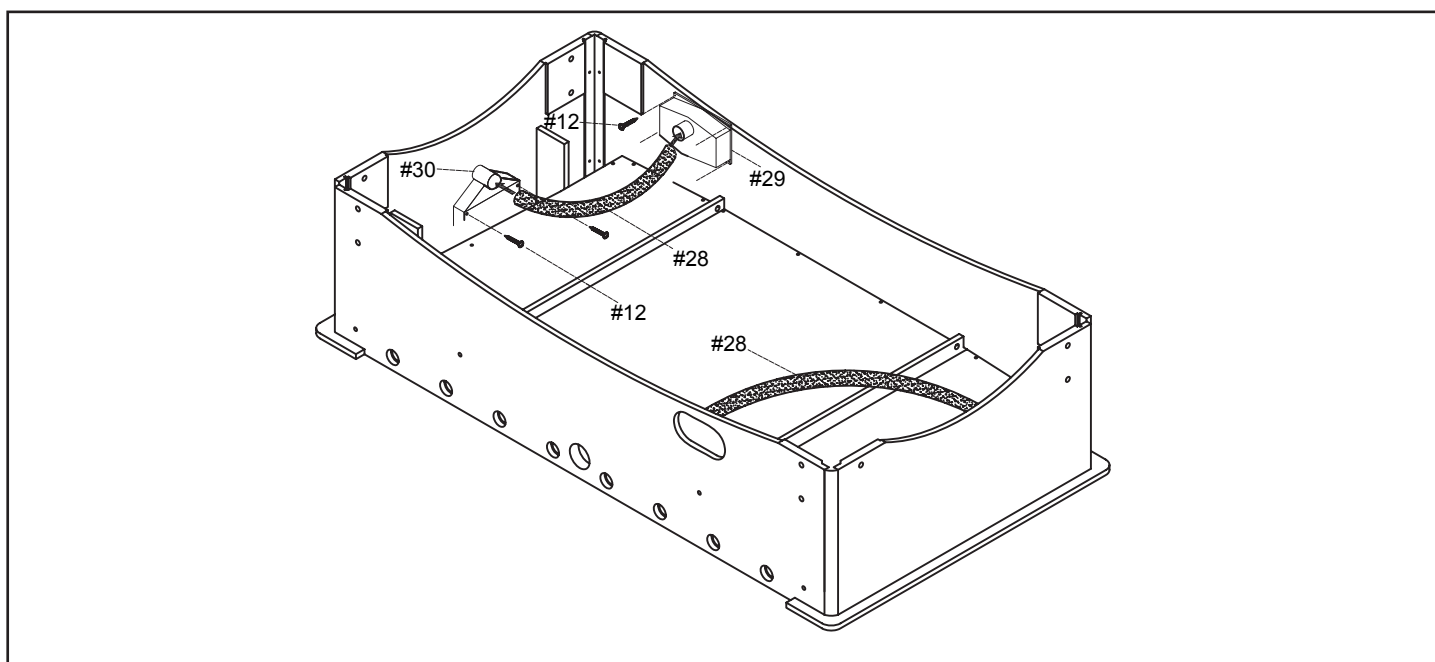

ASSEMBLY INSTRUCTIONS

7. Insert LEG PANEL #6 into both LEGS as shown. *Note: Chrome strip should face out toward ends.* Attach LEFT LEG #4 and RIGHT LEG #5 to each corner of the table with 5/16" BOLT #9 and 5/16" FLAT WASHER #8.
8. Thread one LEG LEVELER #37 onto each LEG. Carefully turn table over.

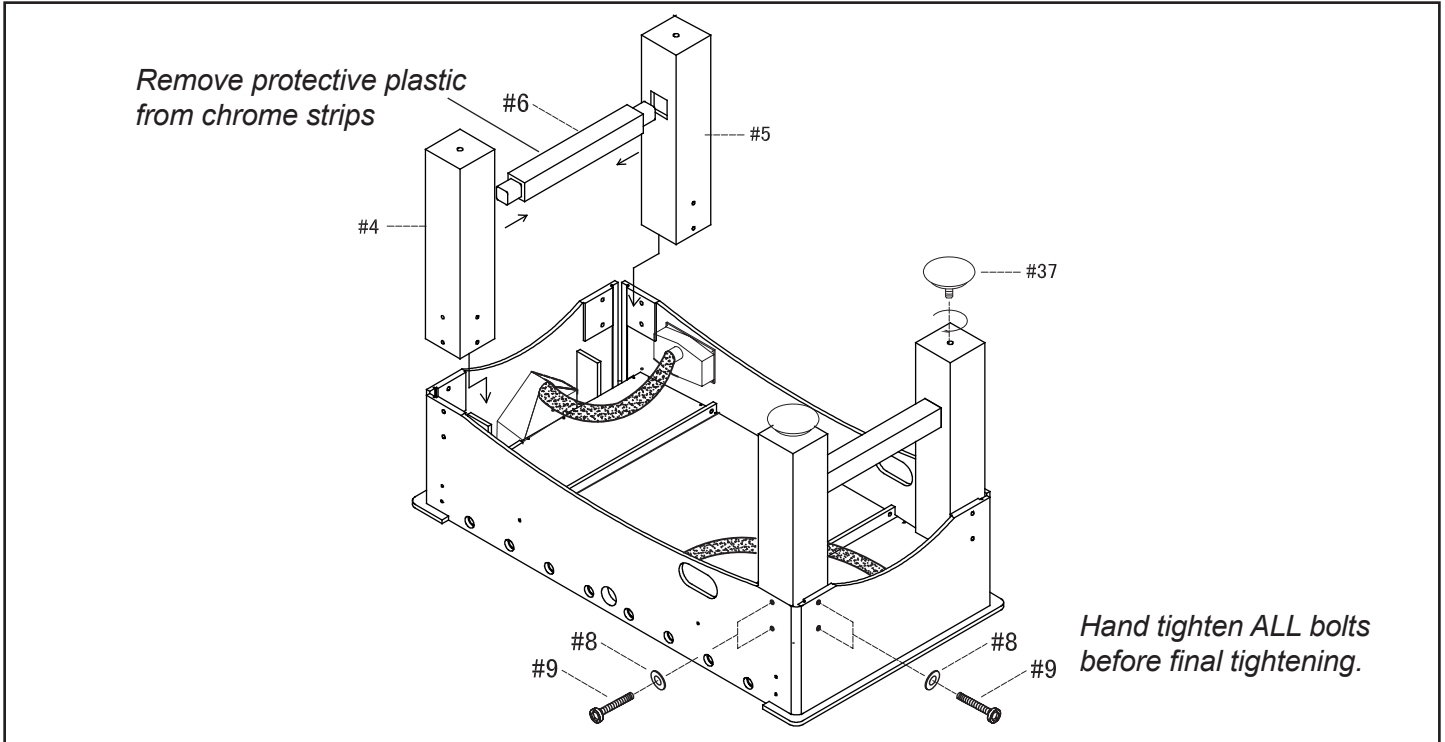

9. Begin PLAYER ROD assembly by partially inserting PLAYER ROD into the appropriate hole in the SIDE PANEL.
10. Before continuing, refer to the diagrams below for correct rod orientation and player placement. *Note: You may choose either color for home or visitor teams.*

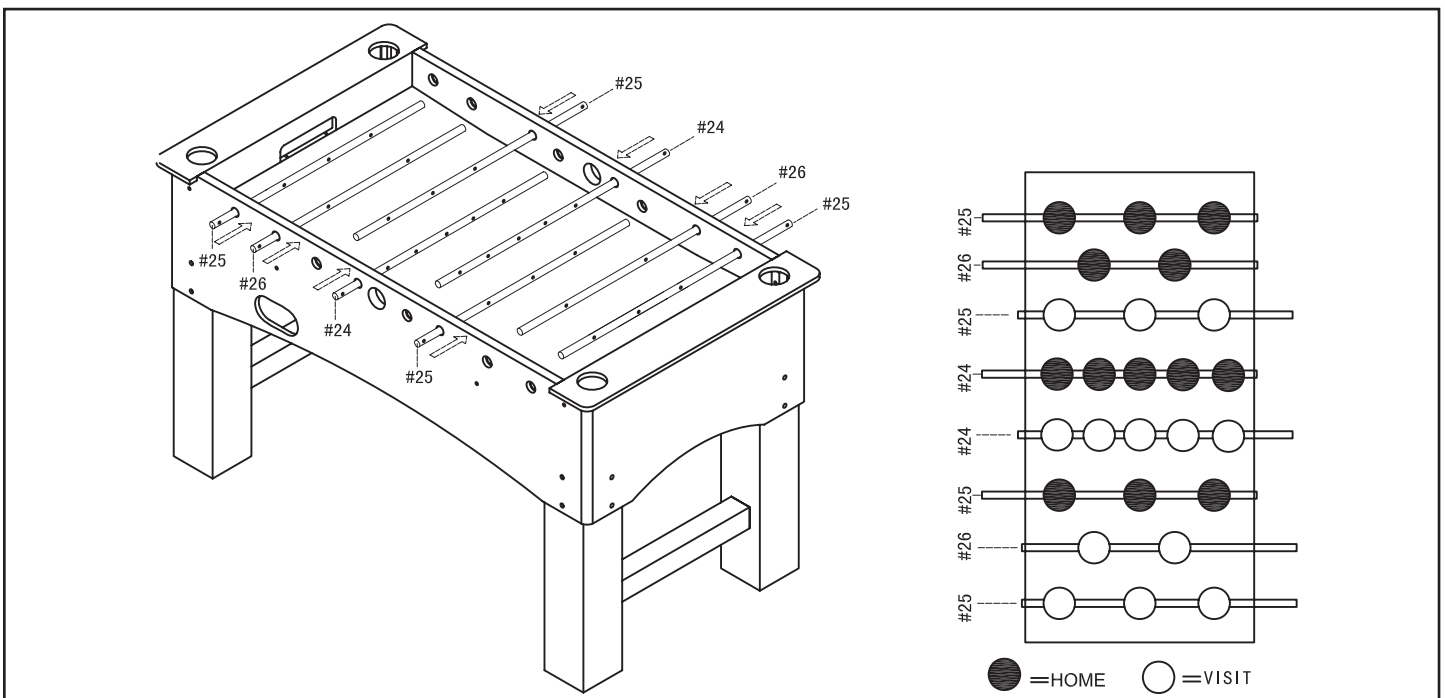

ASSEMBLY INSTRUCTIONS

11. *Note: the HAND GRIP will be attached to the marked end (with hole) of the PLAYER ROD - this end must be inserted into the SIDE PANEL first. Slide one RUBBER BUMPER #21 and PLASTIC ROD WASHER #20 onto the partially inserted PLAYER ROD. Slide the appropriate quantity and color of players onto the PLAYER ROD. Finish PLAYER ROD assembly with PLASTIC ROD WASHER #20 and RUBBER BUMPER #21 (note position for each in diagram below). Insert PLAYER ROD into hole on opposite SIDE PANEL. Fasten PLAYERS to PLAYER ROD with 1-1/8" BOLT #14 and LOCKNUT #15.*

Note: STOP RINGS #38 will be used instead of PLAYERS on either side of the goalies and attached to PLAYER RODS with 1" BOLT #14 (these 4 bolts are slightly shorter than other #14 bolts) and LOCKNUT #15.

12. Repeat assembly with remaining PLAYER RODS. *Note: Each team should face the opposite goal.*

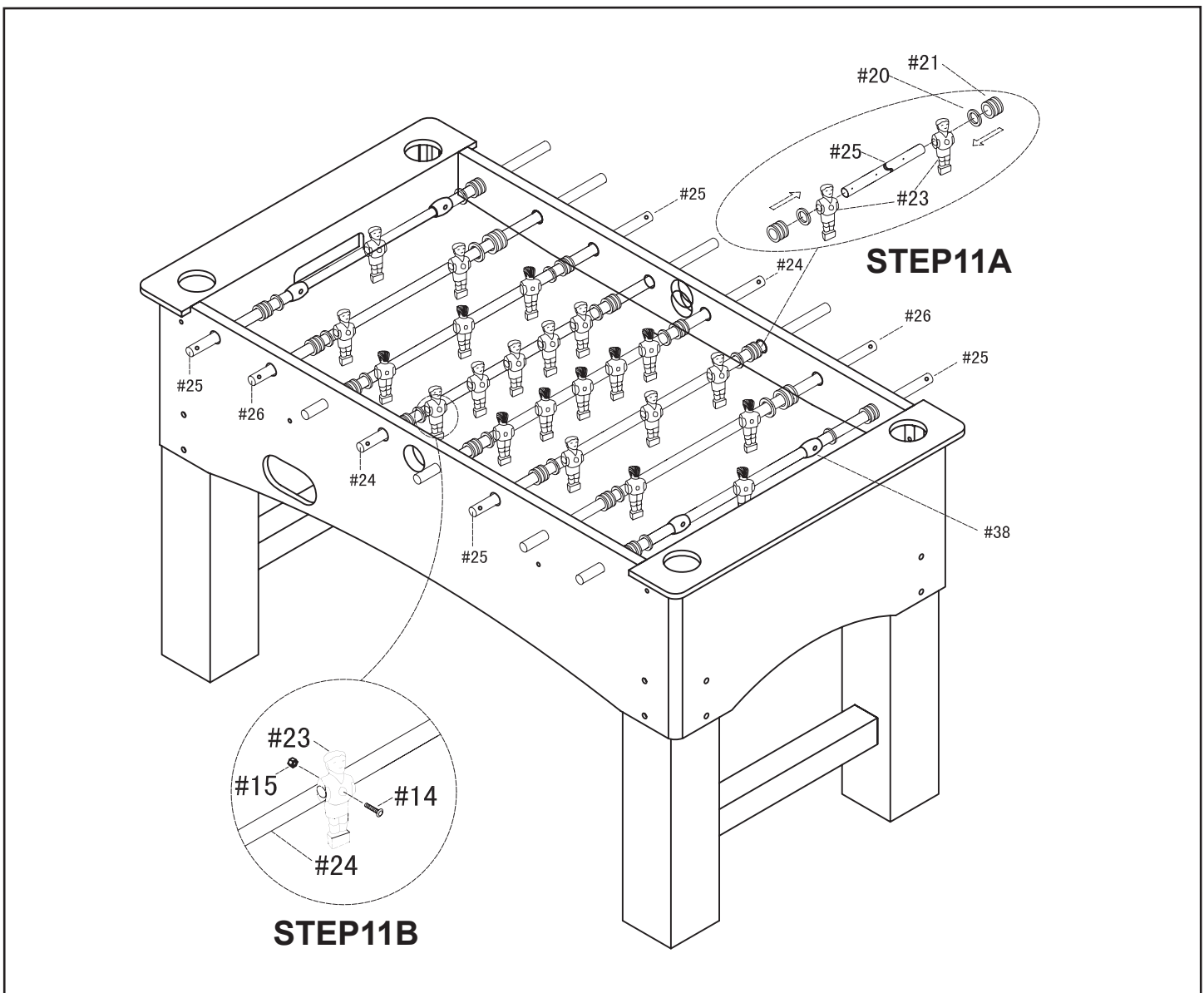

ASSEMBLY INSTRUCTIONS

13. Attach HAND GRIP #19 to the end of the PLAYER ROD with threaded hole using 5/8" BOLT #39. Attach ROD END CAP #36 to the opposite end.
14. Attach one MANUAL SCORER #31 to the top of each END PANEL with 3/4" ROUND HEAD SCREW #17.
15. Attach one TWO-PIECE BALL LAUNCHER #27 to each side of the table by inserting the cup into the hole on the outside of the SIDE PANEL and the launcher into the hole on the inside of the SIDE PANEL and screwing them together. Fasten each to the table with one 1/2" FLAT SCREW #16.
16. Insert SILVER CUP HOLDERS #32 into the holes in the top of each END PANEL as shown.

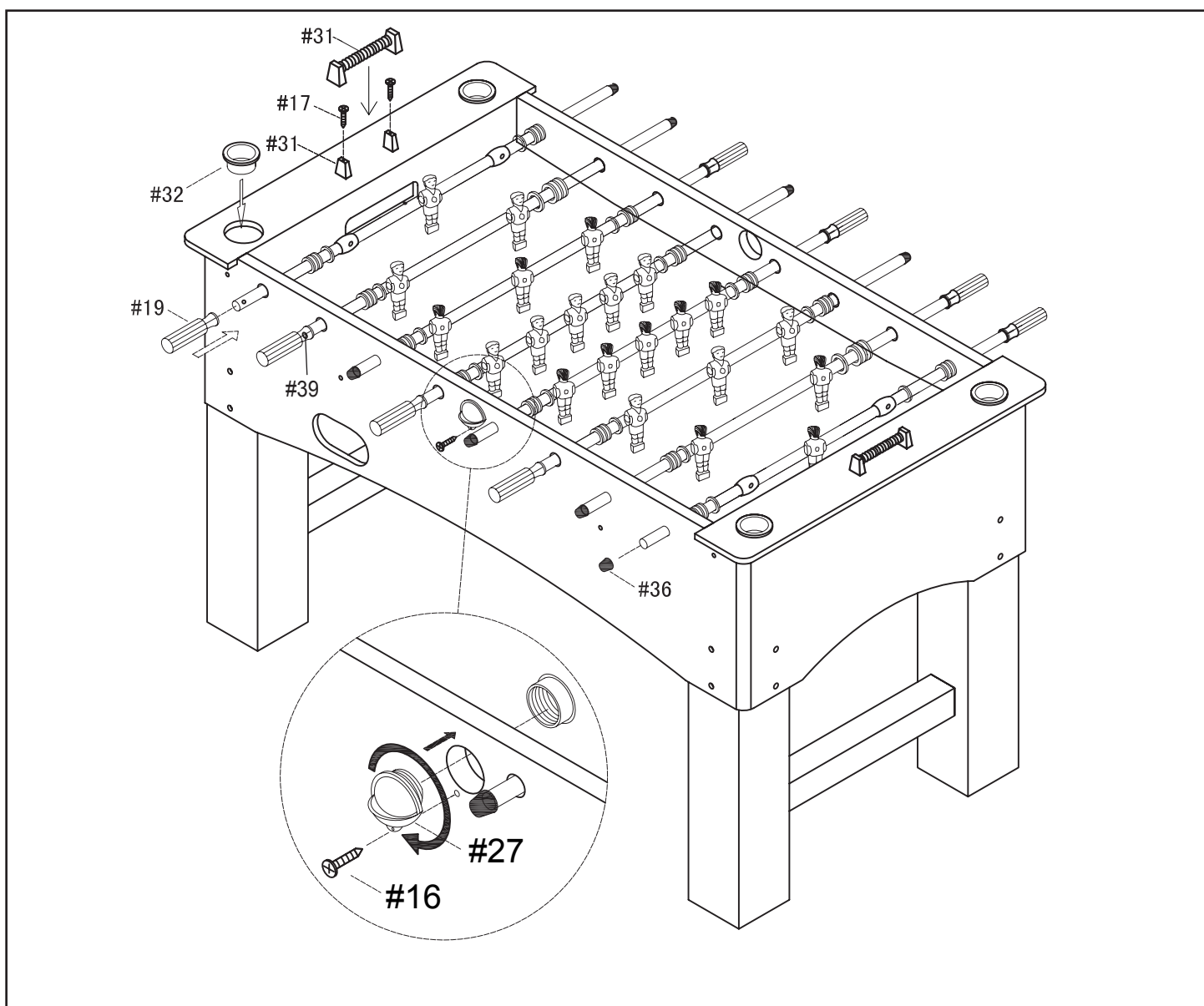

CONGRATULATIONS!

You have now assembled your Soccer Table. Please note the Care and Use instructions below to ensure years of trouble free use of your game table.

CARE AND USE

1. This product is intended for INDOOR use only.
2. Do NOT sit, climb or lean on the table.
3. Do NOT drag the table when moving it as this will damage the legs.

180-DAY LIMITED WARRANTY

This product is warranted to the original purchaser to be free from defects in material or workmanship for a period of 180 days from the date of the original retail purchase.

This warranty does not cover defects or damage due to improper installation, alteration, accident or any other event beyond the control of the manufacturer. Defects or damage resulting from misuse, abuse or negligence will void this warranty. This warranty does not cover scratching or damage that may result from normal usage.

This product is not intended for institutional or commercial use; the manufacturer does not assume any liability for such use. Institutional or commercial use will void this warranty.

This warranty is nontransferable and is expressly limited to the repair or replacement of the defective product. During the warranty period, the manufacturer shall repair or replace defective parts at no cost to the purchaser. Shipping charges and insurance are not covered and are the responsibility of the purchaser. Labor charges and related expenses for removal, installation or replacement of the product or components are not covered under this warranty.

The manufacturer reserves the right to make substitutions to warranty claims if parts are unavailable or obsolete.

The manufacturer shall not be liable for loss of use of the product or other consequential or incidental costs, expenses or damages incurred by the consumer of any other use. The user assumes all risk of injury resulting from the use of this product.

This warranty is expressly in lieu of all other warranties, expressed or implied, including warranties of merchantability or fitness for use to the extent permitted by Federal or state law. Neither the manufacturer nor any of its representatives assumes any other liability in connection with this product.

All warranty claims must be made through the retailer where the product was originally purchased. A purchase receipt or other proof of date of purchase will be required to process all warranty claims. The model number and part numbers found within the assembly instructions will be required when submitting any parts requests or warranty claims.







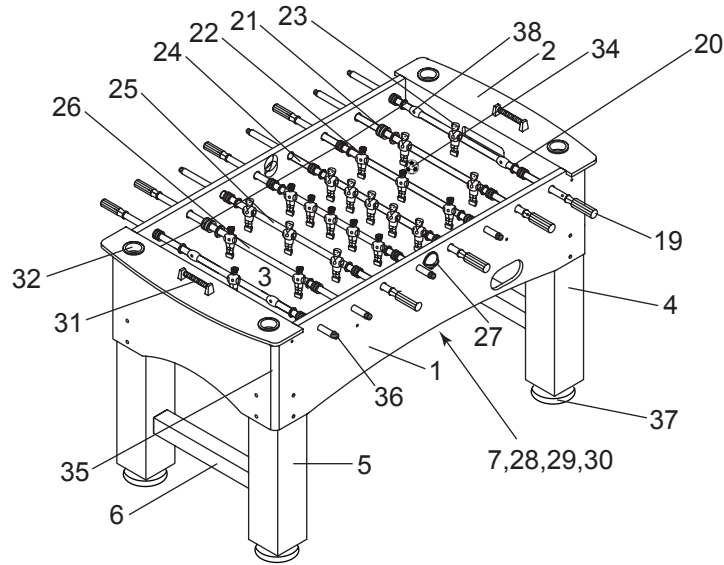





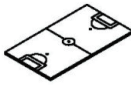













For further warranty information or inquiries, please call 800-759-0977

PRIMO 56" FOOSBALL TABLE - NG1035

Parts List



PARTS

#1 NGP5786  SIDE PANEL	#2 NGP5787  END PANEL	#3 NGP5788  PLAYFIELD	#4 NGP5789  LEG - LEFT	#5 NGP5790  LEG - RIGHT	#6 NGP5791  LEG PANEL	#7 NGP5792  PLAYFIELD SUPPORT BRACE
#19 NGP57931  HAND GRIP	#20 NGP5794  PLASTIC ROD WASHER	#21 NGP5795  RUBBER BUMPER	#22 NGP5796  AWAY PLAYER	#23 NGP5797  HOME PLAYER	#24 NGP5798  5 PLAYER ROD	#25 NGP5799  3 PLAYER ROD
#26 NGP5800  2 PLAYER ROD	#27 NGP5801  2 PIECE BALL LAUNCHER	#28 NGP5802  BALL RUNNER	#29 NGP5803  SIDE BALL CATCHER	#30 NGP5804  BALL CATCHER	#31 NGP5805  MANUAL SCORER	#32 NGP58061  SILVER METAL CUP
#34 NGP5807  SOCCER BALL	#35 NGP5808  APRON CORNER	#36 NGP5809  ROD END CAP	#37 NGP5810  LEG LEVELER	#38 NGP5811  STOP RING		

HARDWARE PACK - NGP5812













#8  5/16" FLAT WASHER	#9  5/16" BOLT	#10  1/4" BOLT	#11  1/4" FLAT WASHER	#12  1/2" SCREW	#13  1" FLAT SCREW	#14  1-1/8" BOLT
#15  LOCKNUT	#16  1/2" FLAT SCREW	#17  3/4" SCREW	#18  1-3/4" SCREW	#33  HEX WRENCH	#39  5/8" BOLT	ADDITIONAL EQUIPMENT REQUIRED:  PHILLIPS HEAD SCREWDRIVER

TABLE DE SOCCER CROSSFIRE 1, 37 m INSTRUCTIONS D'ASSEMBLAGE



Contactez notre
service à la clientèle au
800-759-0977
avec des questions sur le montage
ou l'utilisation de ce produit.

NG1035

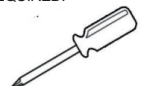
MERCI!

Merci d'avoir acheté notre produit.

Nous travaillons 24 heures sur 24, partout dans le monde, à garantir que nos produits sont de la meilleure qualité possible. Toutefois, dans les rares cas de problèmes lors du montage ou de l'utilisation de ce produit, se il vous plaît communiquer avec notre service à la clientèle au **800-759-0977** pour une aide immédiate avant de contacter votre revendeur.

Pour obtenir de plus amples renseignements, veuillez lire l'information relative à la garantie au verso de ce guide d'instructions.

IMPORTANT! VEUILLEZ LIRE, EN ENTIER, TOUTES LES INSTRUCTIONS AVANT D'ASSEMBLER VOTRE PRODUIT.

TABLEAU D'IDENTIFICATION (LES PIÈCES NE SONT PAS À L'ÉCHELLE)











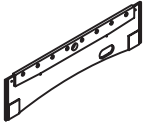
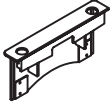
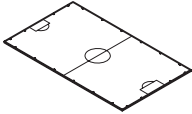

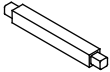

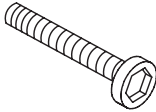
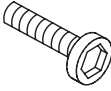

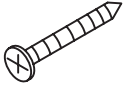
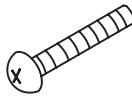

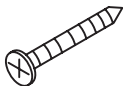



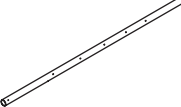
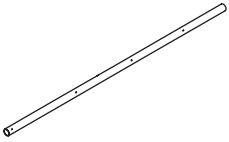
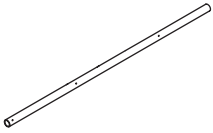
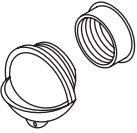
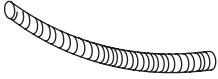
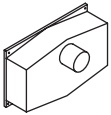
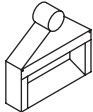
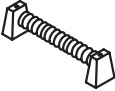

<p>#1</p>  <p>PANNEAU LATÉRAL 2 pièces</p>	<p>#2</p>  <p>PANNEAU D'EXTRÉMITÉ 2 pièces</p>	<p>#3</p>  <p>SURFACE DE JEU 1 pièce</p>	<p>#4</p>  <p>PIED GAUCHE 2 pièces</p>	<p>#5</p>  <p>PIED DROIT 2 pièces</p>
<p>#6</p>  <p>TRAVERSE PIED DE TABLE 2 pièces</p>	<p>#7</p>  <p>TRAVERSE SURFACE DE JEU 2 pièces</p>	<p>#8</p>  <p>RONDELLE (0,79 cm) 16 pièces</p>	<p>#9</p>  <p>BOULON (0,79 cm x 35 mm) 16 pièces</p>	<p>#10</p>  <p>BOULON (0,64 cm x 60 mm) 8 pièces</p>
<p>#11</p>  <p>RONDELLE (0,64 cm) 8 pièces</p>	<p>#12</p>  <p>VIS À TÊTE RONDE (4 x 12 mm) 28 pièces</p>	<p>#13</p>  <p>VIS À TÊTE PLATE (4 x 25 mm) 24 pièces</p>	<p>#14</p>  <p>BOULON (2,86 cm) 26 pièces</p>	<p>#15</p>  <p>ÉCROU 26 pièces</p>
<p>#16</p>  <p>VIS À TÊTE PLATE (4 x 12 mm) 2 pièces</p>	<p>#17</p>  <p>VIS À TÊTE RONDE (4 x 18mm) 4 pièces</p>	<p>#18</p>  <p>VIS À TÊTE RONDE (4 x 45 mm) 4 pièces</p>	<p>#19</p>  <p>POIGNÉE 8 pièces</p>	<p>#20</p>  <p>RONDELLE DE TIGE 16 pièces</p>
<p>#21</p>  <p>BUTOIR DE TIGE 16 pièces</p>	<p>#22</p>  <p>JOUEURS VISITEURS 11 pièces</p>	<p>#23</p>  <p>JOUEURS LOCAUX 11 pièces</p>	<p>#24</p>  <p>TIGE 5 JOUEURS 2 pièces</p>	

TABLEAU D'IDENTIFICATION (LES PIÈCES NE SONT PAS À L'ÉCHELLE)

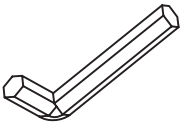
<p>#25</p>  <p>TIGE 3 JOUEURS 4 pièces</p>	<p>#26</p>  <p>TIGE 2 JOUEURS 2 pièces</p>	<p>#27</p>  <p>LANCE BALLE 2 pièces</p>	<p>#28</p>  <p>RÉCUPÉRATEUR DE BALLE 2 pièces</p>
<p>#29</p>  <p>BOÎTE DE RÉCEPTION LATÉRALE 2 pièces</p>	<p>#30</p>  <p>BOÎTE DE RÉCEPTION 2 pièces</p>	<p>#31</p>  <p>MARQUEUR MANUEL 2 pièces</p>	<p>#32</p>  <p>PORTE-GOBELET EN PLASTIQUE ARGENT 4 pièces</p>
<p>#33</p>  <p>CLÉ HEXAGONALE 1 pièce</p>	<p>#34</p>  <p>BALLE DE SOCCER 2 pièces</p>	<p>#35</p>  <p>COIN DE RENFORCEMENT 4 pièces</p>	<p>#36</p>  <p>EMBOUT DE TIGE 8 pièces</p>
<p>#37</p>  <p>PATIN DE NIVELLEMENT 4 pièces</p>	<p>#38</p>  <p>ANNEAU BUTOIR 4 pièces</p>	<p>#39</p>  <p>BOULON (1,59cm) 8 pièces</p>	

Consultez la Liste des pièces, à la fin du guide, pour obtenir le numéro de la pièce.
Pour commander une pièce de rechange, veuillez téléphoner au 1 800 759-0977.

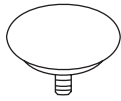
INSTRUCTIONS D'ASSEMBLAGE

1. Déposez votre Table de Hockey sur une surface propre et plane. La table s'assemble à l'envers pour être ensuite retournée sur ses pieds, une fois l'assemblage complété. Cette table est lourde et nécessite au moins deux adultes forts pour la soulever et la retourner.
2. Retirez le contenu de la boîte, avant de commencer l'assemblage, assurez-vous d'avoir toutes les pièces telles que listées et illustrées au tableau d'identification. Avis : certaines pièces sont préassemblées ou préinstallées.
3. Certaines illustrations ou dessins peuvent ne pas ressembler au produit que vous avez acheté. Veuillez lire et comprendre les instructions avant de compléter chaque étape d'assemblage.
4. Quand vous fixez en place une pièce avec plus d'une vis ou écrou, veuillez, en premier, les visser à la main et terminer la fixation avec un tournevis ou une clé.
5. Un tournevis électrique peut être utile lors de l'assemblage, mais veuillez le régler à basse torque et l'utiliser avec prudence; si la torque est trop élevée, la vis peut se défaire ou être trop serrée.

AVERTISSEMENTS!

LIRE TOUTES LES INSTRUCTIONS D'ASSEMBLAGE ET LES CONSIGNES DE SÉCURITÉ ATTENTIVEMENT.

RISQUE D'ÉTOUFFEMENT – CERTAINS ÉLÉMENTS DU PRODUIT CONTIENNENT DE PETITES PIÈCES - NE CONVIENT PAS À UN ENFANT DE MOINS DE TROIS ANS.

INSTRUCTIONS POUR L'ASSEMBLAGE

1. Installez la SURFACE DE JEU (no 3), avec le côté fini tourné vers le bas, sur le rebord du PANNEAU LATÉRAL (no 1). Avis : la table est assemblée à l'envers.

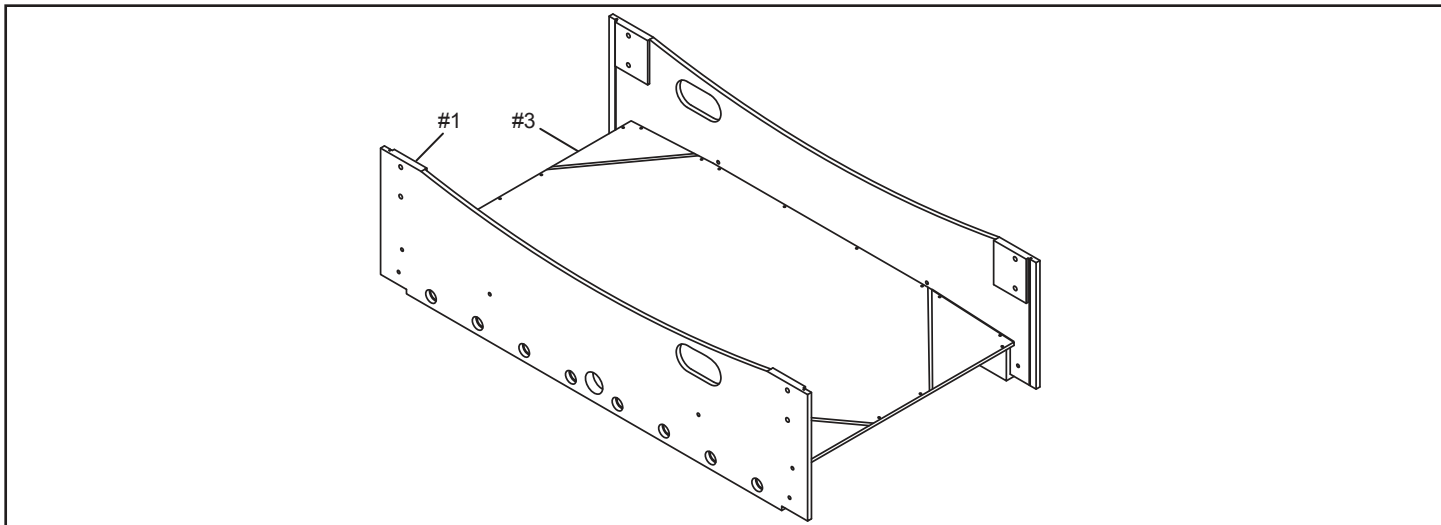

2. Installez un PANNEAU D'EXTRÉMITÉ (no 2) à chaque extrémité de la table à l'aide de boulons (no 10) et de rondelles (no 11).

3. Fixez la SURFACE DE JEU à la table à l'aide de vis à tête plate (no 13) en utilisant les trous prépercés. Avis : Utilisez toujours des trous pré-perçés. Sinon, des dommages permanents peuvent se faire à la table. Une lampe de poche peut être utile en alignant les trous. Il peut être utile d'avoir une deuxième personne poussée sur le côté opposé, que vous attachez surface de jeu, pour cadrer jusqu'à la surface. Assurez-vous que les panneaux d'extrémité épousent la forme contre les panneaux latéraux avant vissage surface de jeu.

4. Insérez les COINS DE RENFORCEMENT (no 35) dans les PANNEAUX LATÉRAUX (no 1) et les PANNEAUX D'EXTRÉMITÉ (no 2) aux quatre coins. Avis: Assurez-vous que l'intérieur des trous de vis sont positionnées en haut.

5. Serrer de boulon, lâche serrés à l'étape 2, des deux côtés.

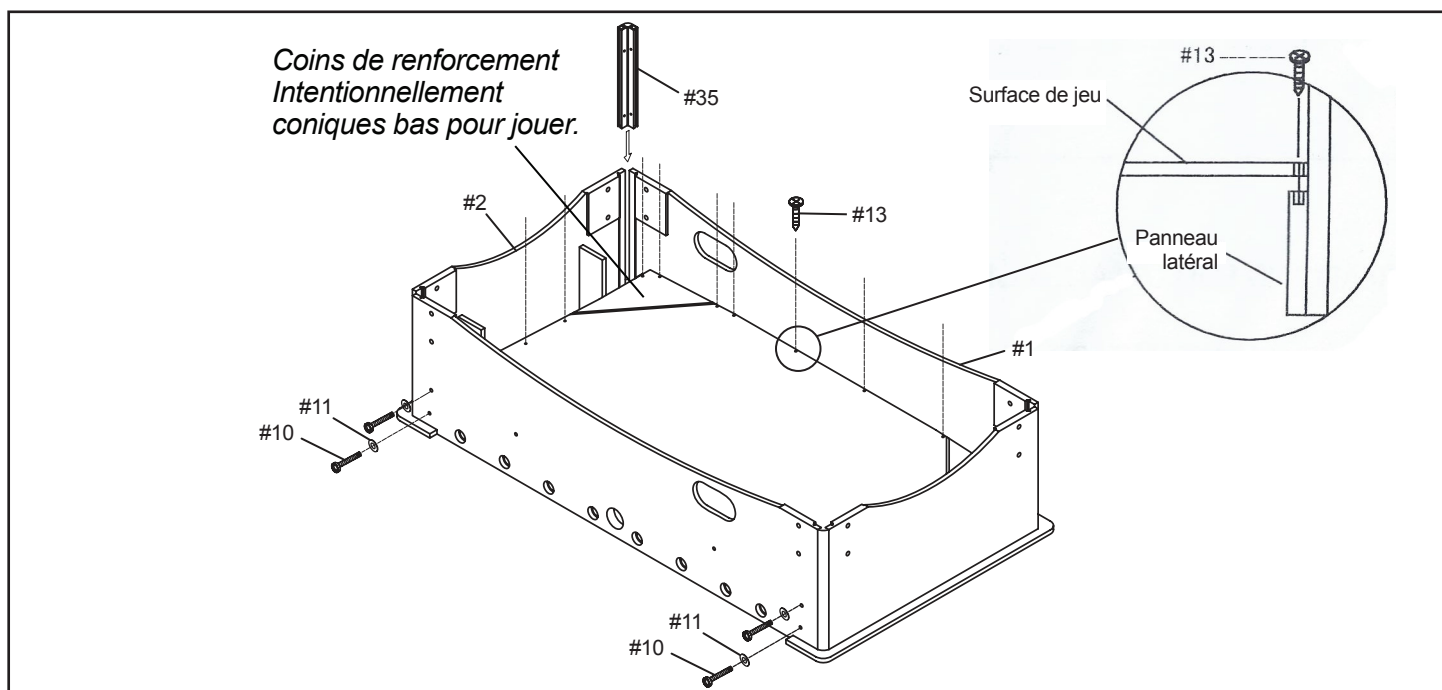

INSTRUCTIONS POUR L'ASSEMBLAGE

6. Installez chacune des TRAVERSES SURFACE DE JEU (no 7) entre les PANNEAUX LATÉRAUX, tel qu'illustré ci-dessous. Fixez les TRAVERSES SURFACE DE JEU (no 7) à l'aide de vis (no 18). Insérez les COINS DE RENFORCEMENT à chaque coin de la table à l'aide de vis (no 12).

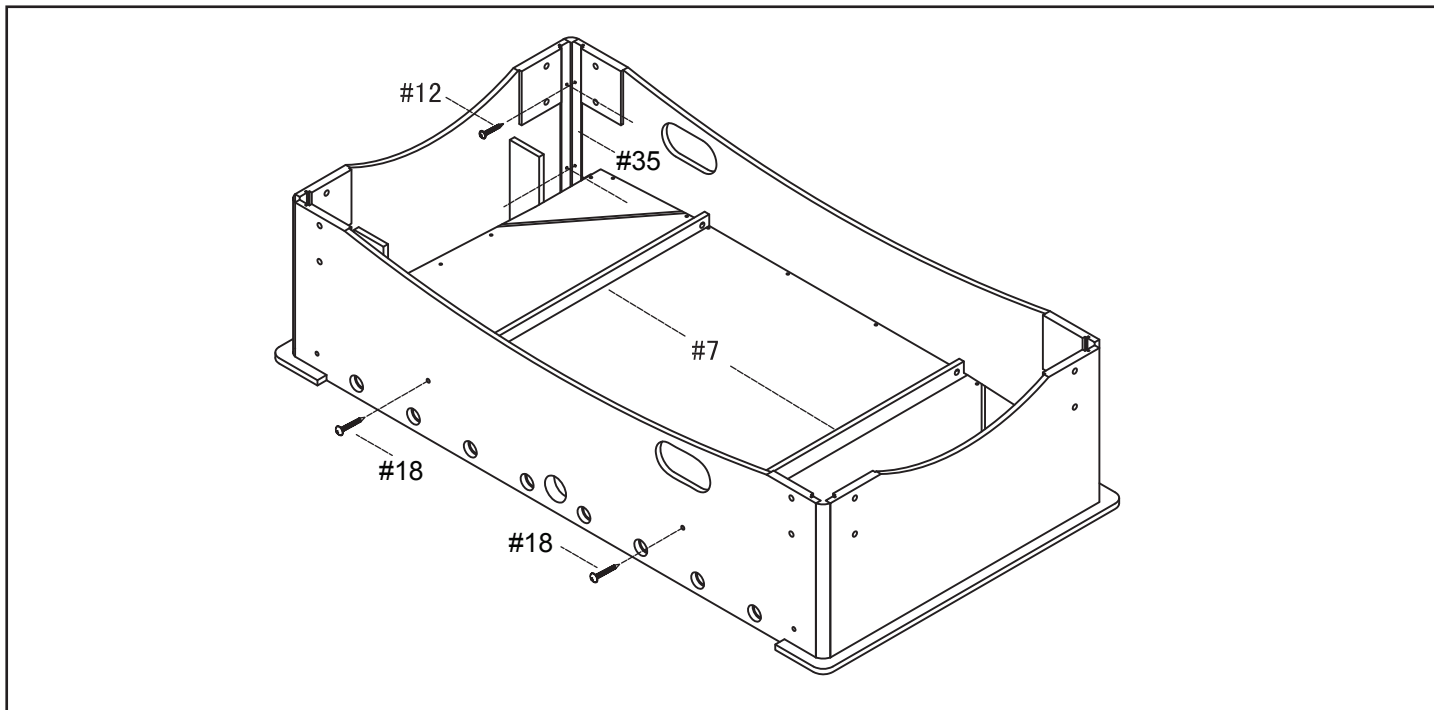

7. Installez la BOÎTE DE RÉCEPTION LATÉRALE (no 29) à chacun des PANNEAUX LATÉRAUX à l'aide de vis (no 12). Fixez la BOÎTE DE RÉCEPTION (no 30) à chacun des PANNEAUX D'EXTRÉMITÉ à l'aide de vis (no 12). Installez le RÉCUPÉRATEUR DE BALLES (no 28) sur la BOÎTE DE RÉCEPTION LATÉRALE et la BOÎTE DE RÉCEPTION, tel qu'illustré ci-dessous.

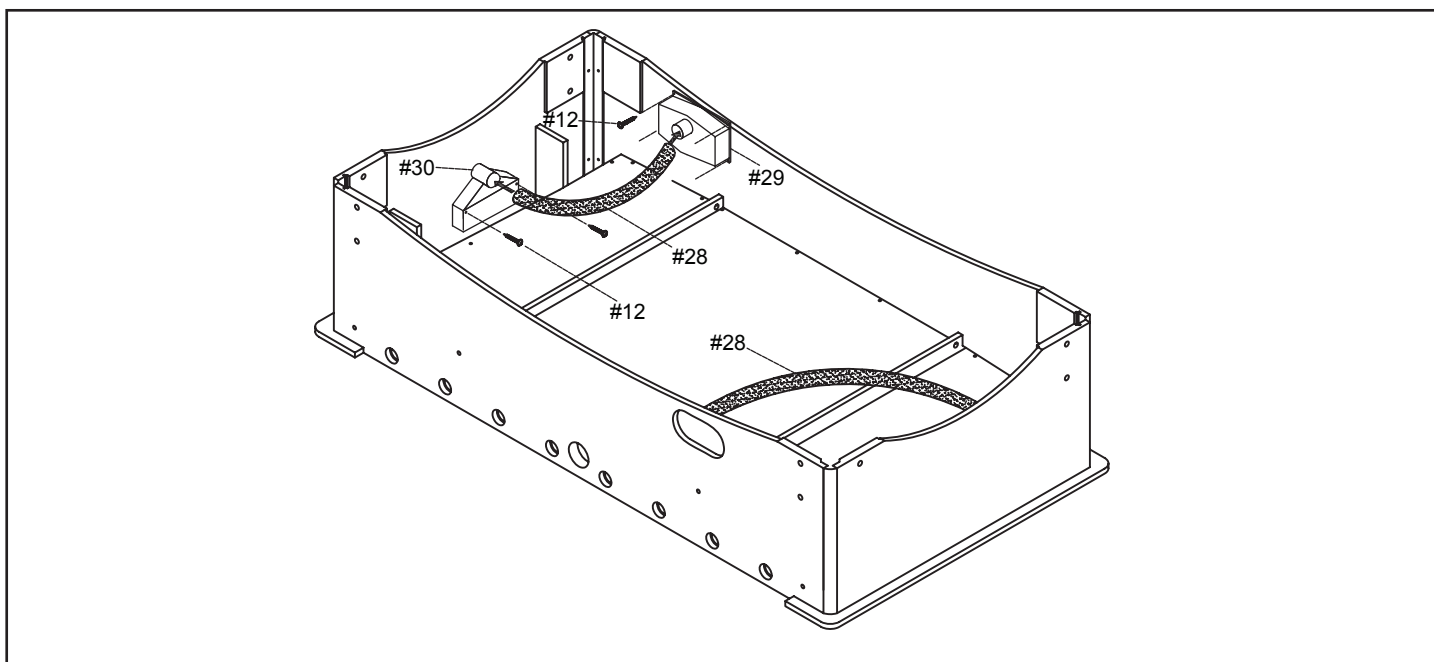

INSTRUCTIONS POUR L'ASSEMBLAGE

8. Insérez la TRAVERSE PIED DE TABLE (no 6), tel qu'illustré ci-dessous. Fixez les PIEDS GAUCHES (no 4) et les PIEDS DROITS (no 5) aux coins de la table à l'aide de boulons (no 9) et de rondelles (no 8).

9. Fixez un PATIN DE NIVELLEMENT (no 37) à chaque PIED. Retournez la table avec précaution.

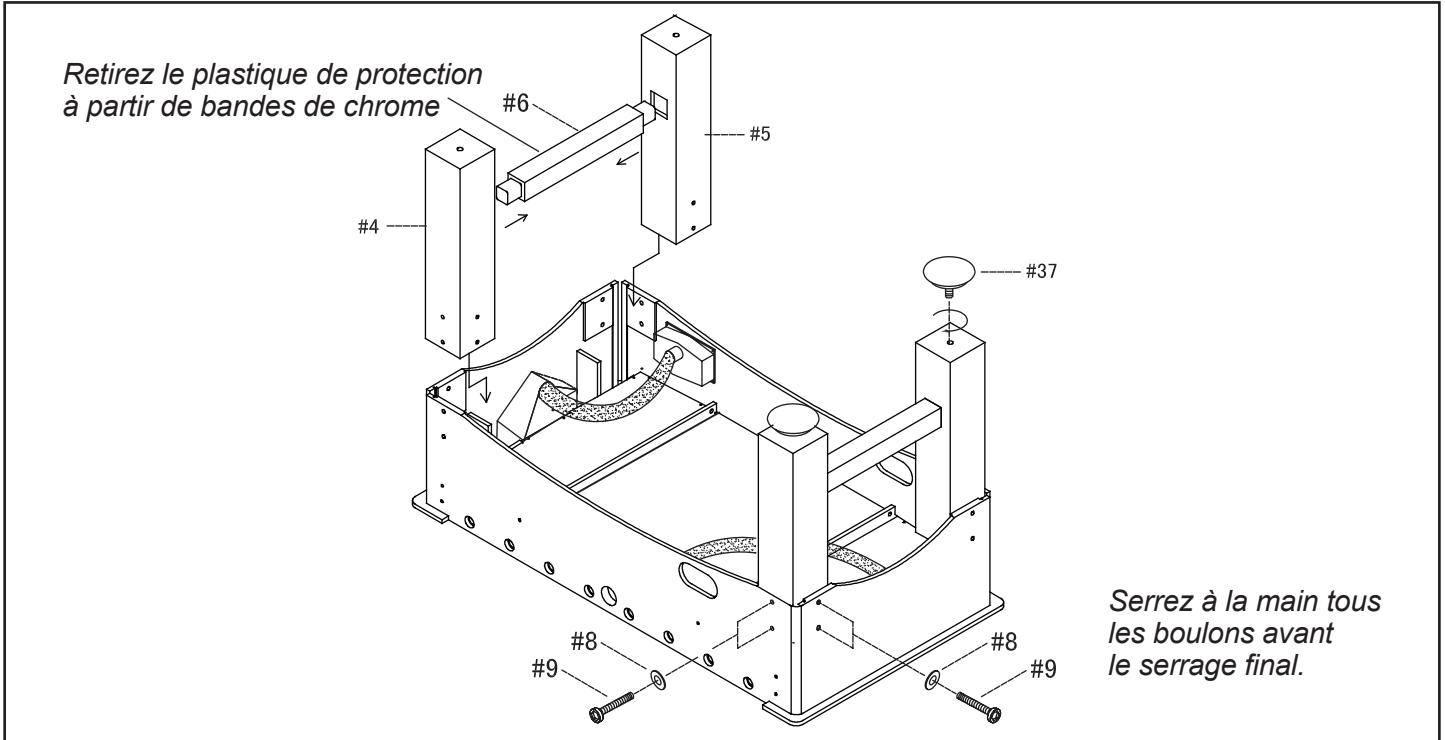

10. Commencez l'assemblage des TIGES DE JOUEURS en insérant partiellement la TIGE DE JOUEURS dans l'ouverture appropriée du PANNEAU LATÉRAL.

11. Avant de poursuivre, consultez les schémas ci-dessous pour savoir comment placer les tiges et les joueurs. Avis : Vous pouvez choisir une couleur pour l'équipe de joueurs locaux ou celle des visiteurs.

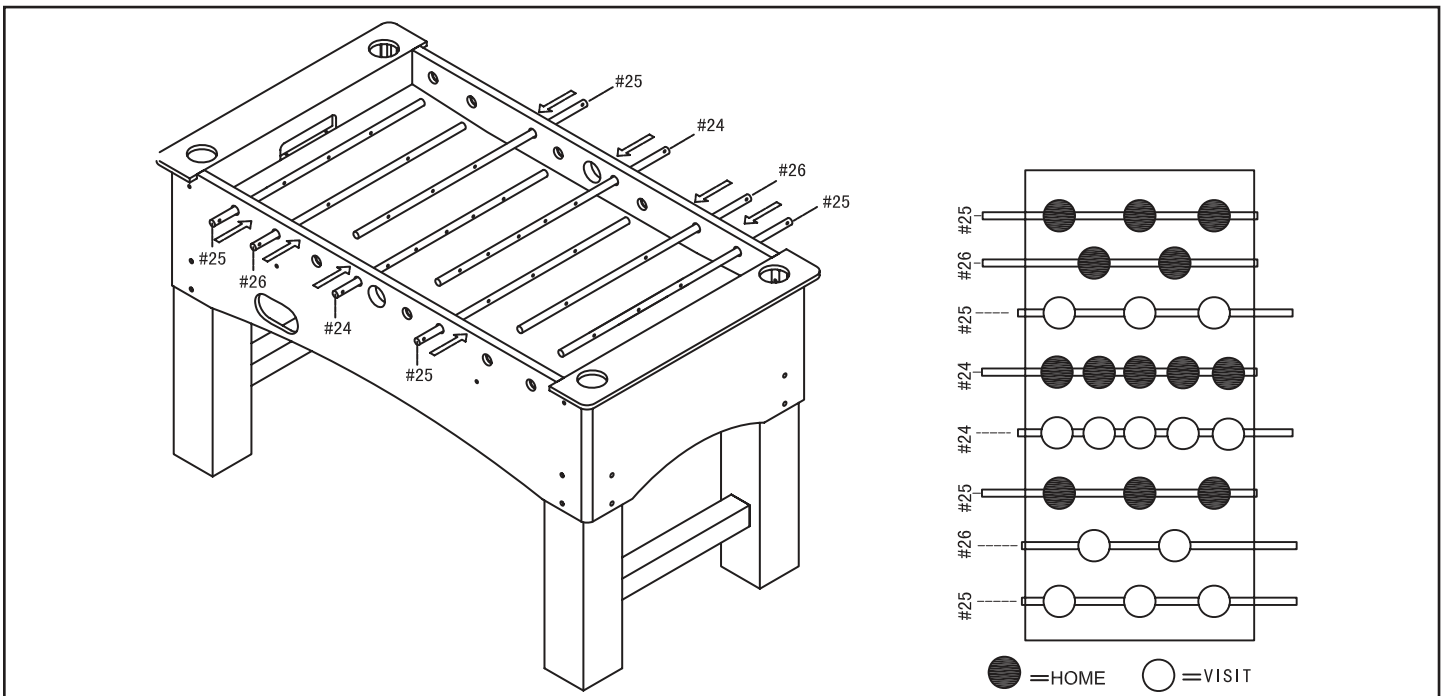

INSTRUCTIONS POUR L'ASSEMBLAGE

12. AVIS: La POIGNÉE sera fixée à l'extrémité de la TIGE DE JOUEURS, à l'endroit indiqué (tige avec un trou) - cette extrémité doit être insérée dans le PANNEAU LATÉRAL en premier. Faites ensuite glisser un BUTOIR DE TIGE (no 21) et une RONDELLE DE PLASTIQUE (no 20) sur la TIGE DE JOUEURS partiellement insérée. Faites glisser le bon nombre de joueurs de la bonne couleur sur la TIGE DE JOUEURS. Terminez l'assemblage des TIGES DE JOUEURS avec la RONDELLE DE PLASTIQUE (no 20) et le BUTOIR DE TIGE (no 21). Veuillez noter la position de chaque tige dans le schéma ci-dessous. Insérez une TIGE DE JOUEURS dans l'ouverture du PANNEAU LATÉRAL opposé. Placez les JOUEURS sur la TIGE DE JOUEURS avec des BOULONS (no 14) et des ÉCROUS (no 15).

AVIS: Les ANNEAUX BUTOIR (no 38) seront utilisés plutôt que les JOUEURS sur les côtés des gardiens de but et seront fixés sur les TIGES DE JOUEURS avec des BOULONS (no 14) et des ÉCROUS (no 15).

13. Poursuivez l'assemblage des autres TIGES DE JOUEURS. Avis : Chaque équipe doit faire face au gardien du but.

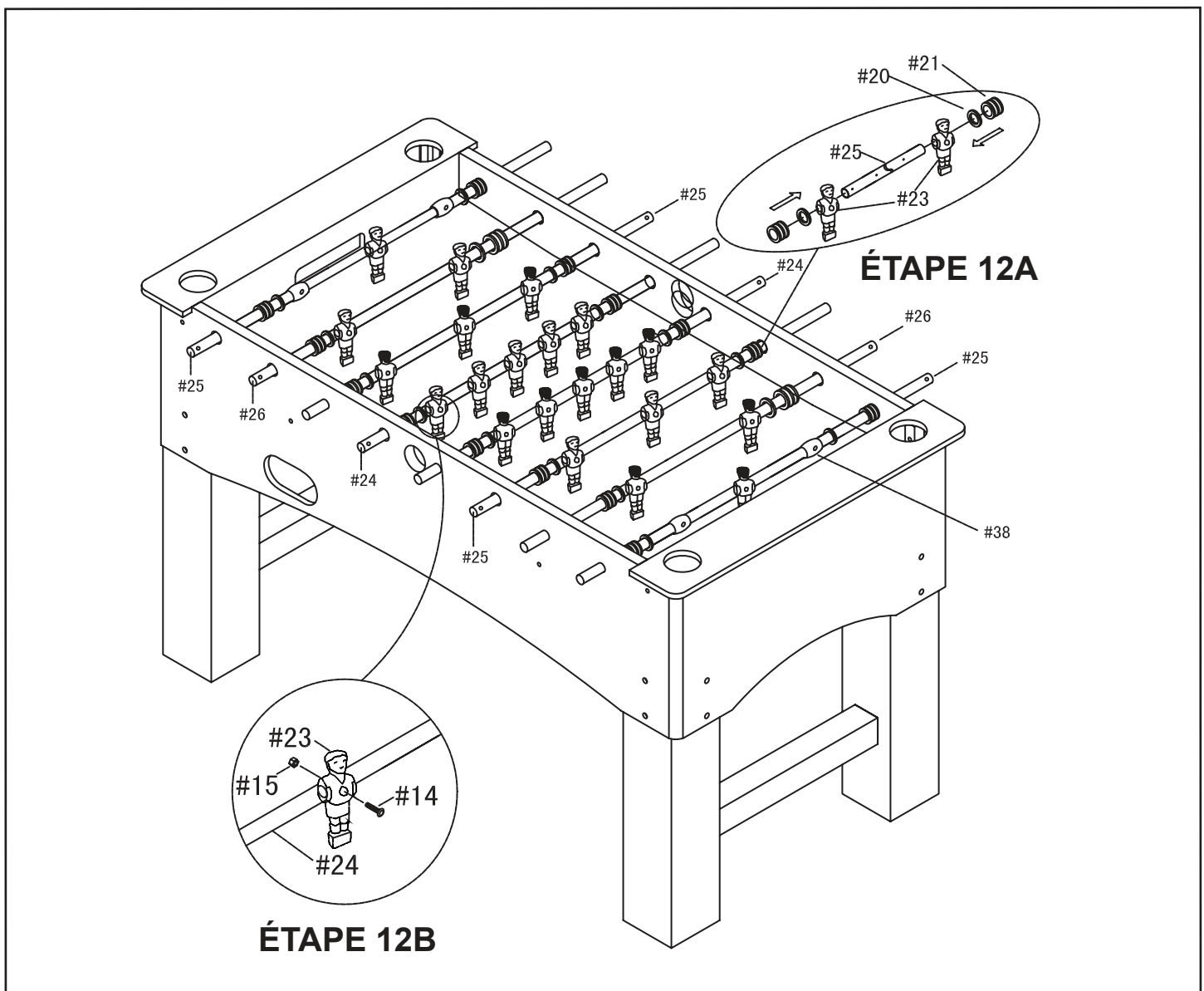

INSTRUCTIONS POUR L'ASSEMBLAGE

14. Installez une POIGNÉE (no 19) à l'extrémité des TIGES DE JOUEURS spécialement identifiées. Fixez un EMBOUT de TIGE (no 36) à l'autre extrémité.
15. Installez le MARQUEUR MANUEL (no 31) au-dessus de chaque PANNEAU D'EXTRÉMITÉ à l'aide des vis à tête ronde (no 17).
16. Fixez une pièce du LANCE BALLE (no 27) de chaque côté de la table en l'insérant dans l'orifice d'entrée de la balle à l'extérieur du PANNEAU LATÉRAL et l'autre pièce du LANCE BALLE dans l'orifice d'entrée à l'intérieur du PANNEAU LATÉRAL, tel qu'illustré ci-dessous. Utilisez les vis à tête plate (no 16) pour les fixer à la table.
17. Insérez PORTE-GOBELET (no 32) dans les trous sur le dessus de chaque panneau d'extrémité, comme indiqué.

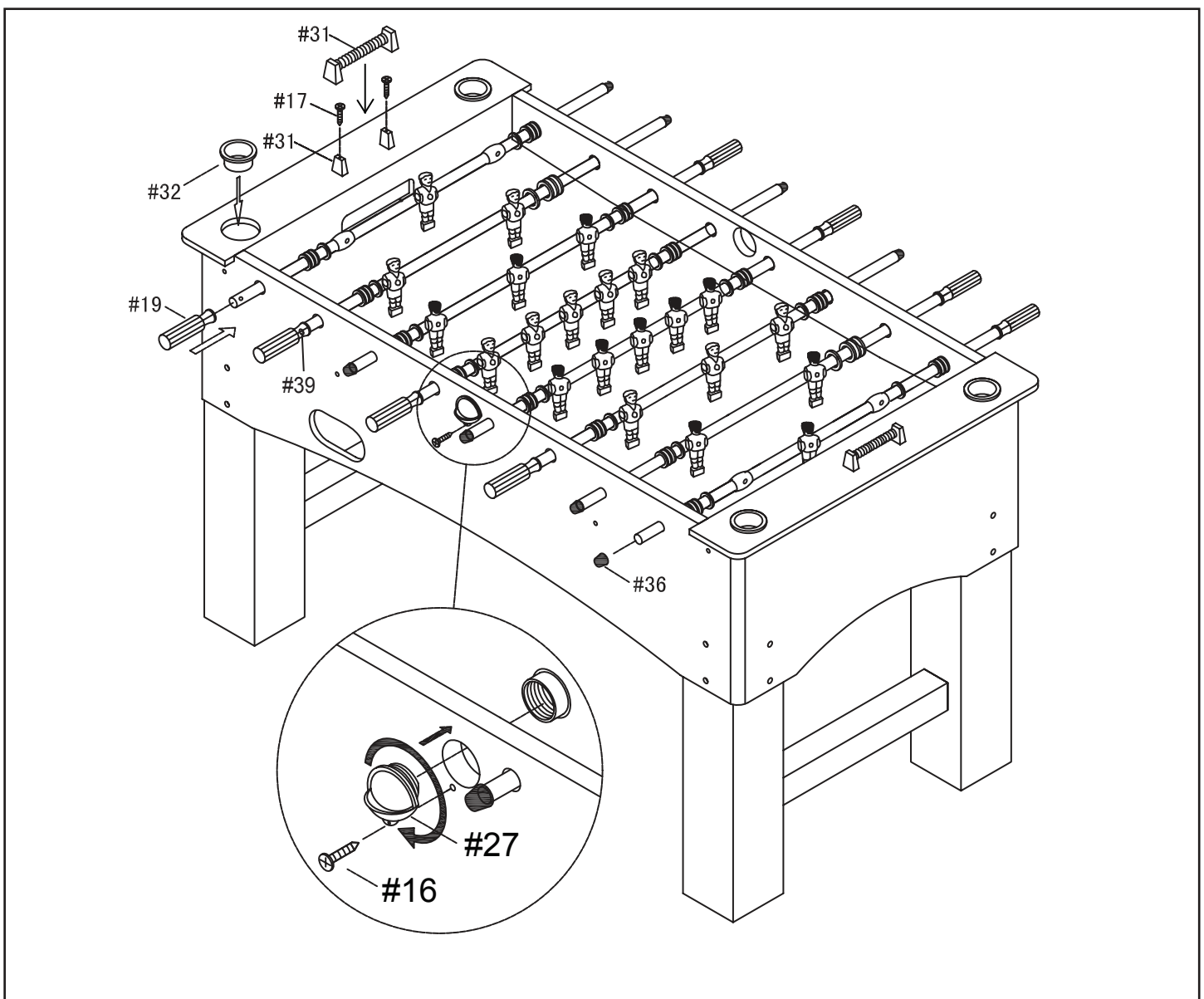

FÉLICITATIONS!

VOUS AVEZ ASSEMBLÉ VOTRE TABLE DE HOCKEY.
VEUILLEZ CONSULTER LES INSTRUCTIONS D'ENTRETIEN
ET D'UTILISATION, CI-DESSOUS, AFIN DE CONSERVER
VOTRE TABLE DE JEU LONGTEMPS.

ENTRETIEN ET UTILISATION

1. Ce produit doit être utilisé à l'INTÉRIEUR seulement.
2. NE PAS s'asseoir, grimper ou s'appuyer sur la table de jeu.
3. NE PAS tirer sur la table pour la déplacer, cela risque d'endommager les pieds de la table.

GARANTIE LIMITÉE DE 180 JOURS

La garantie du produit est valide pour l'acheteur original en ce qui a trait aux pièces défectueuses ou à la main-d'œuvre pour une période de 180 jours de la date d'achat.

Cette garantie n'est couverte pas les dommages causés par accident, par modification, par une installation défectueuse ou tout autre événement hors du contrôle du fabricant. Tout défaut ou dommage résultant de la négligence ou d'une mauvaise utilisation annule cette garantie. La présente garantie ne couvre pas les égratignures ou les dommages attribuables à un usage normal.

Ce produit n'est pas destiné à un usage institutionnel ou commercial; le fabricant décline toute responsabilité pour une telle utilisation. Un usage institutionnel ou commercial annule cette garantie.

Cette garantie est non transférable et est expressément limitée à la réparation ou au remplacement du produit défectueux. Au cours de la période de garantie, le fabricant s'engage à remplacer et à réparer les pièces défectueuses sans frais pour l'acheteur. Les frais d'assurance et d'expédition ne sont pas couverts et sont à la charge de l'acheteur. Les frais de main-d'œuvre et les dépenses liées au déplacement, à l'installation ou au remplacement du produit ou de ses composantes ne sont pas couverts par cette garantie.

Le fabricant se réserve le droit de faire des substitutions de recours en garantie si la pièce n'est pas disponible ou obsolète.

Le fabricant décline toute responsabilité liée à la perte d'utilisation ainsi que tous les autres coûts directs ou indirects, frais ou dommages encourus par le consommateur qui aurait été causés par une autre utilisation. L'utilisateur assume tous les risques de dommage résultant de l'utilisation de ce produit.

Cette garantie tient lieu expressément de toute autre garantie, exprimée ou implicite, y compris les garanties de qualité marchande ou d'adaptation à un emploi particulier dans la mesure permise par les lois fédérales ou provinciales. Ni le fabricant, ni aucun de ses représentants n'assument aucune autre responsabilité en rapport avec ce produit.

Toute réclamation doit être faite par le détaillant où le produit a été acheté. Une facture ou autre preuve d'achat est nécessaire pour traiter toutes les réclamations de garantie. Le numéro de modèle et les numéros de référence figurant dans les instructions d'assemblage seront exigés lors de la soumission de demande de pièces ou de recours en garantie.







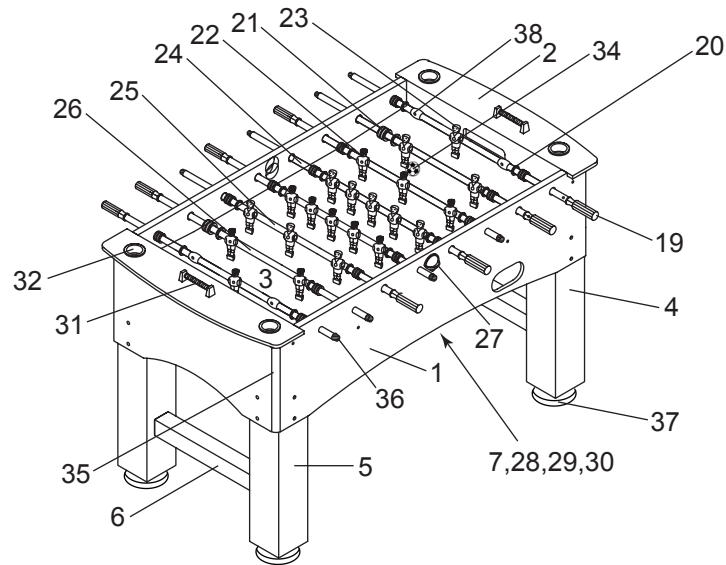





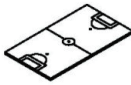



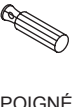







Pour plus d'information ou pour toute question, veuillez téléphoner au 1 800 759-0977.

TABLE DE FOOSBALL PRIMO (1,42 cm) - NG1035













Liste des pièces



Pièces

#1 NGP5786  PANNEAU LATÉRAL	#2 NGP5787  PANNEAU D'EXTRÉMITÉ	#3 NGP5788  SURFACE DE JEU	#4 NGP5789  PIED GAUCHE	#5 NGP5790  PIED DROIT	#6 NGP5791  TRAVERSE PIED DE TABLE	#7 NGP5792  TRAVERSE SURFACE DE JEU
#19 NGP57931  POIGNÉE	#20 NGP5794  RONDELLE PLASTIQUE TIGE DE JOUEURS	#21 NGP5795  BUTOIR DE TIGE	#22 NGP5796  JOUEUR VISITEUR	#23 NGP5797  JOUEUR LOCAL	#24 NGP5798  TIGE 5 JOUEURS	#25 NGP5799  TIGE 3 JOUEURS
#26 NGP5800  TIGE 2 JOUEURS	#27 NGP5801  LANCE BALLE	#28 NGP5802  RÉCUPÉRATEUR DE BALLE	#29 NGP5803  BOÎTE DE RÉCEPTION LATÉRALE	#30 NGP5804  BOÎTE DE RÉCEPTION	#31 NGP5805  MARQUEUR MANUEL	#32 NGP58061  PORTE-GOBELET EN PLASTIQUE ARGENT
#34 NGP5807  BALLE DE SOCCER	#35 NGP5808  COIN DE RENFORCEMENT	#36 NGP5809  EMBOUT DE TIGE	#37 NGP5810  PATIN DE NIVELLEMENT	#38 NGP5811  ANNEAU BUTOIR		

Le sac de quincaillerie NGP5812 comprend

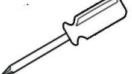
#8  RONDELLE (0,79 cm)	#9  BOULON (0,79 cm x 35 mm)	#10  BOULON (0,64 cm x 60 mm)	#11  RONDELLE (0,64 cm)	#12  VIS À TÊTE RONDE (1,27 cm)	#13  VIS À TÊTE PLATE (2,54 cm)	#14  BOULON (2,86 cm)
#15  ÉCROU	#16  VIS À TÊTE PLATE (1,27 cm)	#17  BOULON (1,90 cm)	#18  BOULON (4,45 cm)	#33  CLÉ HEXAGONALE	#39  BOULON (1,59cm)	ÉQUIPEMENT ADDITIONNEL REQUIS:  TOURNEVIS CRUCIFORME