

MIDTOWN 6' AIR HOCKEY TABLE - NG1037

Spec Sheet

UPC Code: 672875903139

2-color graphic on gloss white 1/8" MDF play surface with approx. 1,950 holes in 1" square grid pattern over 1/2" air plenum that is baffled to control air flow. Table body and support structure are 5/8" MDF.

Battery operated LED display scorer with motion sensor wiring to goals and speaker for sound effects including timer and multiple game settings. Requires four AA batteries.

Goal Opening: 9.875" W x .5" with a black angled ABS puck deflector and 1" black female velcro strip across top 1/2" of goal to keep puck in goal box.

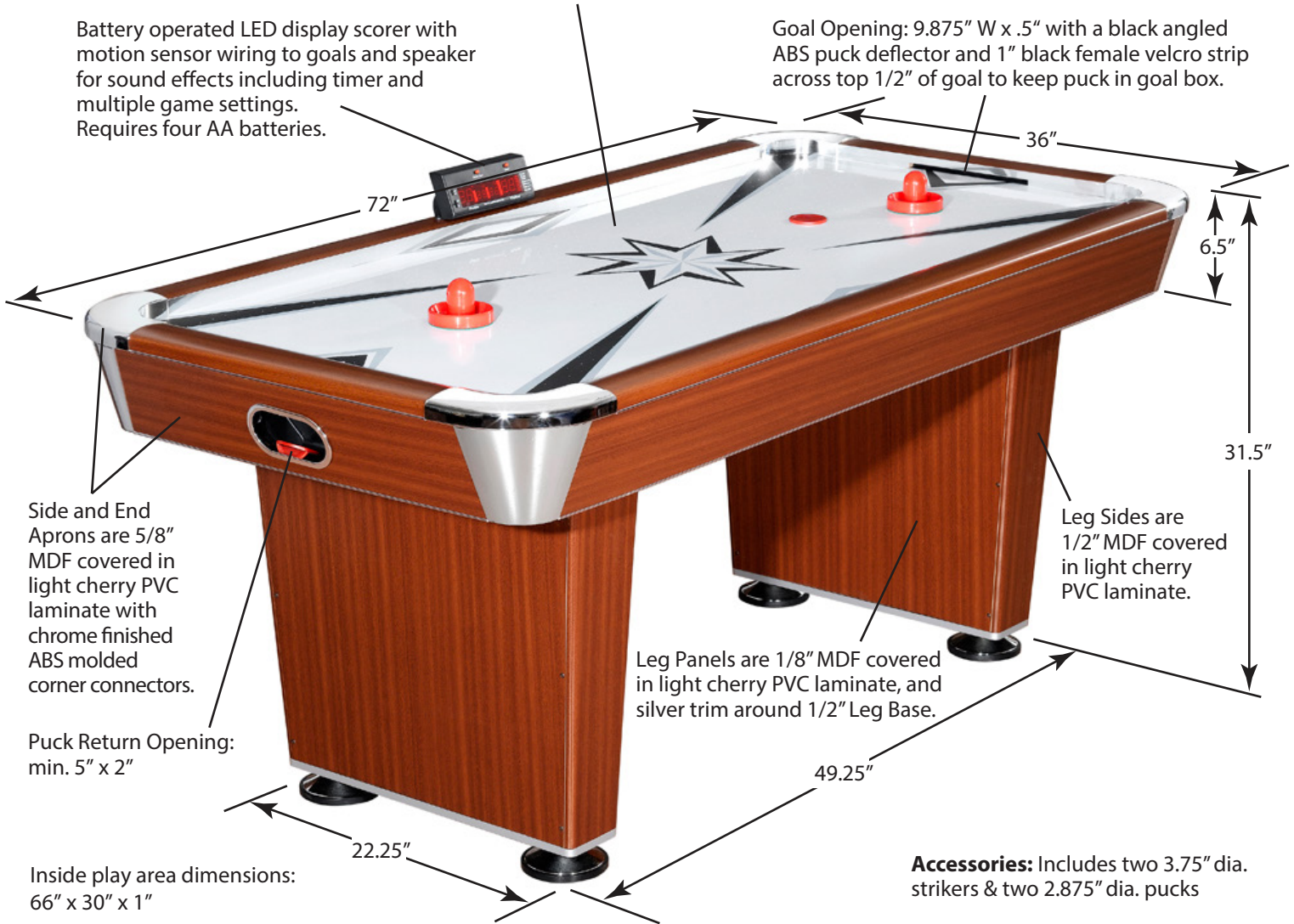

Side and End Aprons are 5/8" MDF covered in light cherry PVC laminate with chrome finished ABS molded corner connectors.

Puck Return Opening: min. 5" x 2"

Inside play area dimensions: 66" x 30" x 1"

Leg Panels are 1/8" MDF covered in light cherry PVC laminate, and silver trim around 1/2" Leg Base.

Leg Sides are 1/2" MDF covered in light cherry PVC laminate.

Accessories: Includes two 3.75" dia. strikers & two 2.875" dia. pucks

All structural components are CARB certified MDF



UL approved ON/OFF switch and blower

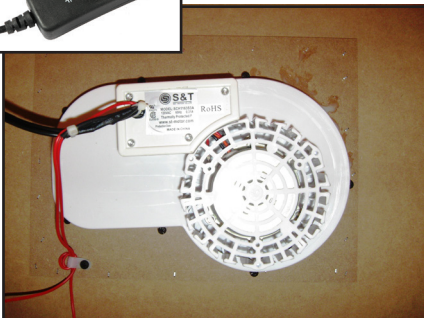

Securely mounted turbo blade blower, AC120V 60 Hz 0.31A, with a min. 9" x 12" mounting board.



8" x 3" x 2.25" LED electronic timer and scoring system with multiple game options. Requires 4 AA batteries.









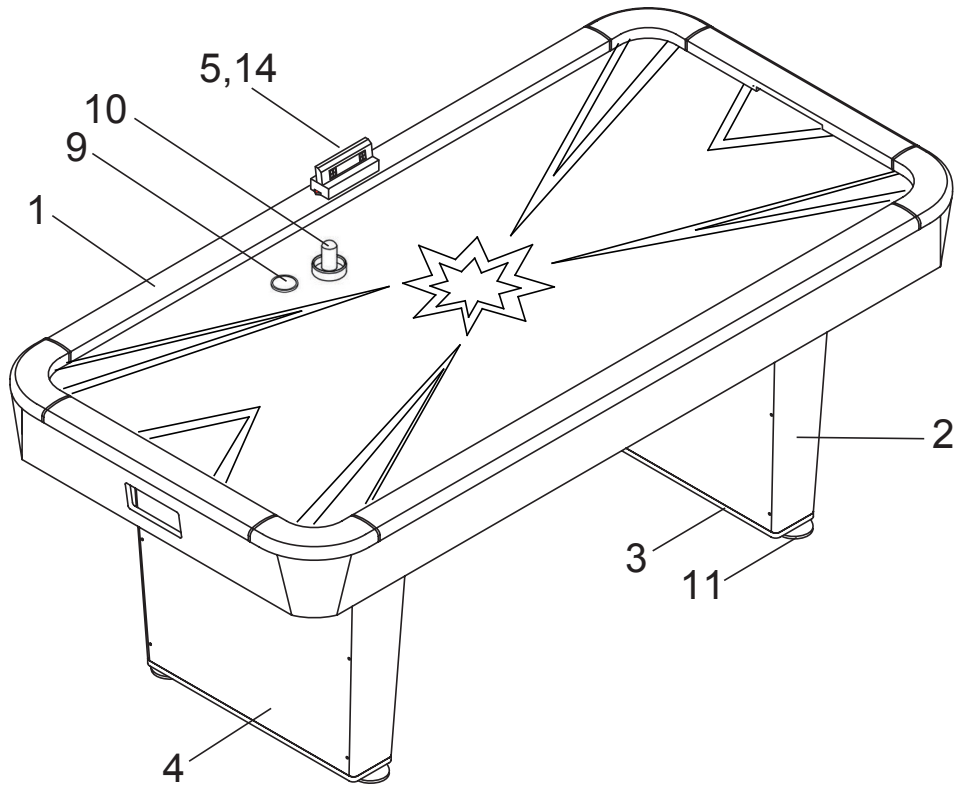

5/8" support structure and leg attachment method.

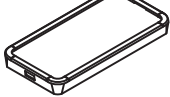
MIDTOWN 6' AIR HOCKEY TABLE - NG1037





Spec Sheet



PARTS

#1 NGP5841 72" x 36" x 6.5" 1/2" MDF  TABLE BODY x1	#2 NGP5842 27.625" x 6" 1/2" MDF  LEG x4	#3 NGP5843 22.25" x 4.25" 1/2" MDF  LEG BASE x2	#4 NGP5844 23.75" x 21.125" 1/8" MDF  LEG PANEL x4	#5 NGP5845 8" x 3" x 2.25", 4 AA batteries reqd.  ELECTRONIC SCORER x1	#9 NGP5774 2.875" Dia. x 1/8" ABS Plastic  PUCK x2	#10 NGP5773 3.75" Dia. x 2.5" H ABS Plastic w/ Felt Pad  STRIKER x2
#11 NGP5848 5" Dia. x 1.75" ABS & Metal  LEG LEVELER x4	NGP5889 AC 120V Blower Pre-installed on Table Body  BLOWER MOTOR	#14 NGP58451 (A & B wires: 1 wire set per goal) SCORER SENSOR WIRE	<p><i>All dimensions given are approx. and represent the size at the widest point of that dimension.</i></p>			

HARDWARE PACK - NGP5846 (sealed in individual numbered poly bags and then bagged as set)

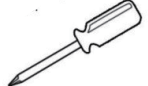
#6 x12  FLAT WASHER	#7 x8  1-3/4" SCREW	#8 x26  5/8" SCREW	#12 x1  HEX WRENCH	#13 x12  BOLTS	ADDITIONAL EQUIPMENT REQUIRED:  PHILLIPS HEAD SCREWDRIVER
---	---	--	--	---	--