



musiccityfire
the evolving sound of fire

SOUND REACTIVE FIRE SYSTEMS



SMART DEVICE
CONTROLLED



BLUETOOTH
CONNECTED



INTEGRATED
SOUND



LED
LIGHTING

Music City Fire System MANUAL

Certified by CSA International Meets: ANSI Z21.20-2014 &
CSA C22.2 60730-2-5-14



music city fire
the evolving sound of fire

! WARNING !

Recommended installation by a professional locally licensed for gas piping. Improper installation, adjustment, modification, service, or maintenance can cause injury or property damage. Read the complete user manual thoroughly before installing or servicing the Music City Fire System.

FEATURES

Control flame heights with the control panel, WiFi, or the mobile app.
Multiple audio sources: WiFi, Bluetooth, USB, Auxiliary Input
Compatible with 30W LED strip with multiple modes.
USB output port for charging.

BOX 1 CONTENTS

- A. Control Panel
- B. Valve Box
- C. Power Adapter (10 ft)
- D. 3.5mm Audio Cable
- E. Data Transfer Cable (3 ft)

BOX 2 CONTENTS

- A. Matte Black Burner Pan
- B. Stainless Steel Burner
- C. 3 ft Regulator
- D. Black Flex Line
- E. Pilot Line
- F. Pilot System (Installed in Burner Pan)

BOX 3 CONTENTS

- A. 6" Harman / Kardon Speakers (x2)
- B. Speaker Wire (x2)

800.XXX.XXXX
MUSICCITYFIRECOMPANY.COM

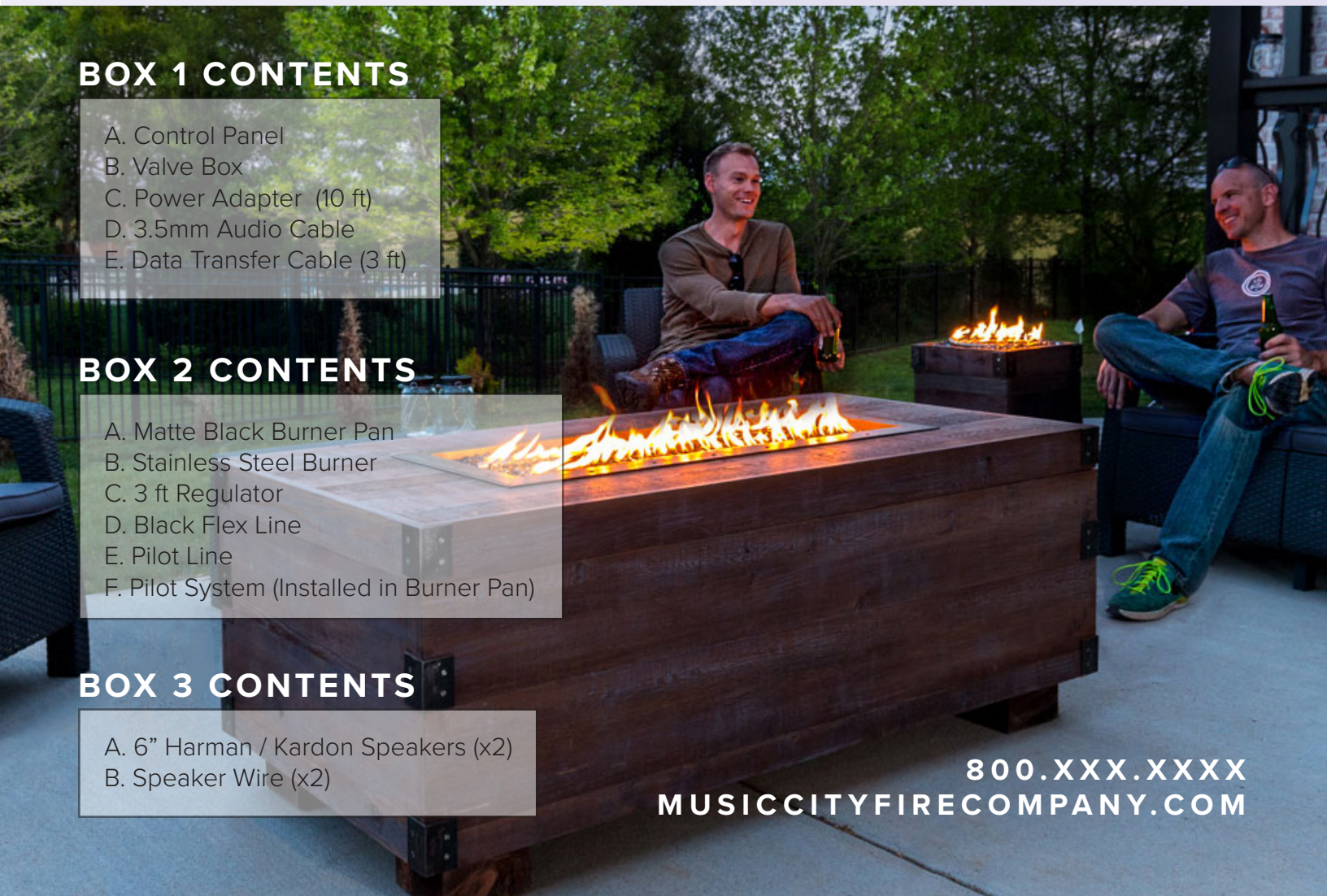
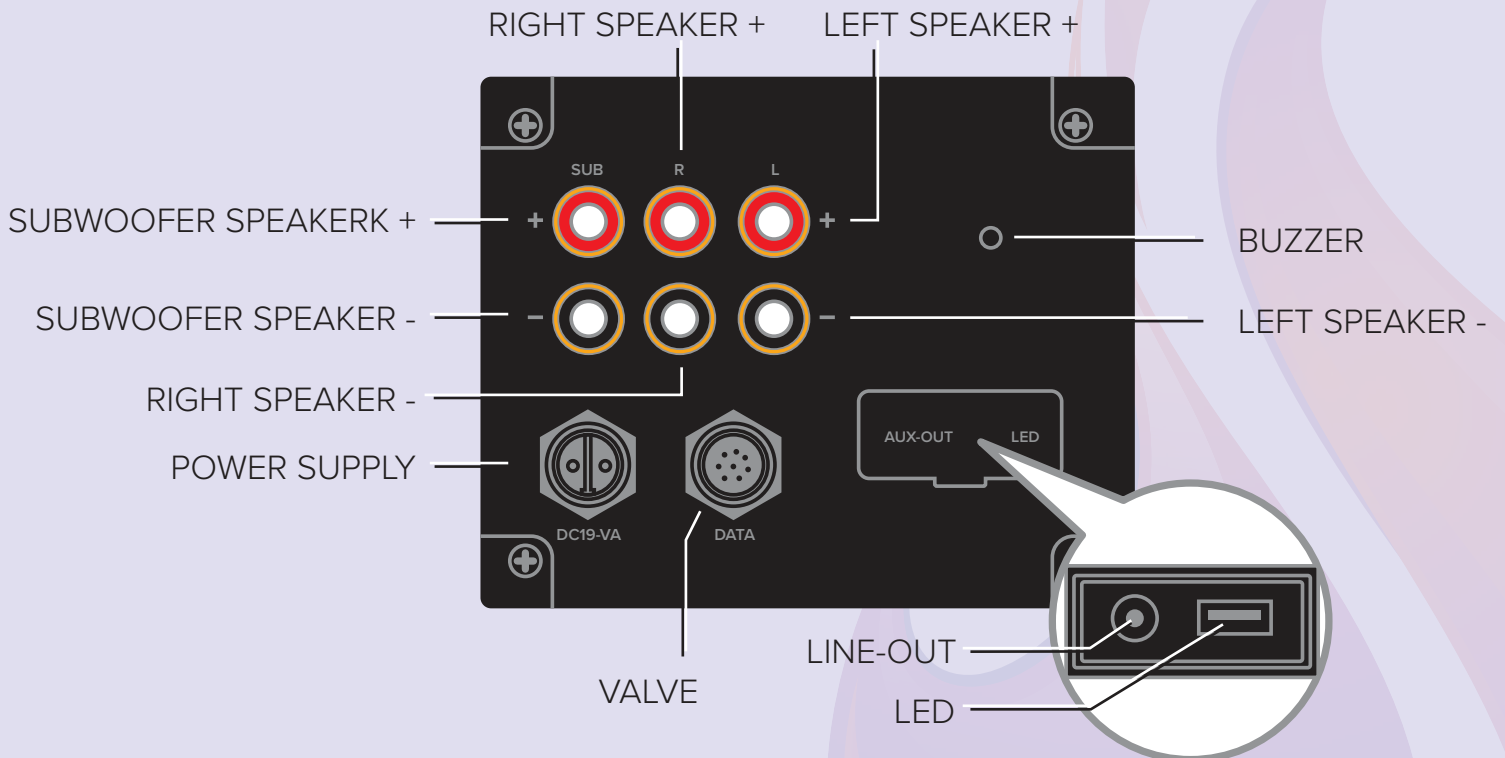

DIAGRAM OF CONTROLLER



STEP 1: ASSEMBLY OF SOUND REACTIVE FIRE SYSTEM

Connect the LPG regulator hose / NG hose to the brass input port of the valve box (in shipping box 1) (*fig. 1*).

Use the flex line to connect the burner and the valve box to the brass output port on the valve (*fig. 2*).

Attach the tube (copper/mini flex line) from the ignition fixture to the pilot output port on the valve box (*fig. 3*).

Attach the electronic cable to the connectors in the ignition fixture, the red end to the ignition (the longer pin) and the black one to the flame detector (the shorter pin) (*fig. 4*).

Use the 8-core data transferring cable to connect the controller to the valve box. (*fig. 5*). Be sure to screw back the aerial protective head.

Optional: Plug in the LED strip to the LED slot in the back of the controller by following the polarity arrows. (*fig. 6*).

Connect the speaker to the Line-Out Slot in the back of the Controller by following the correct polarities (*fig. 7*).

Plug in the AC/DC adapter (19V/4.74A) to the back of the power socket of the Controller (*fig. 8*).

When the connection is completed, check all connection points to make sure they're properly installed, especially at the gas pipes and joints to avoid risk of gas leakage. After you confirm the system has been properly installed without any leaks, turn on the safety valve on the fuel source.

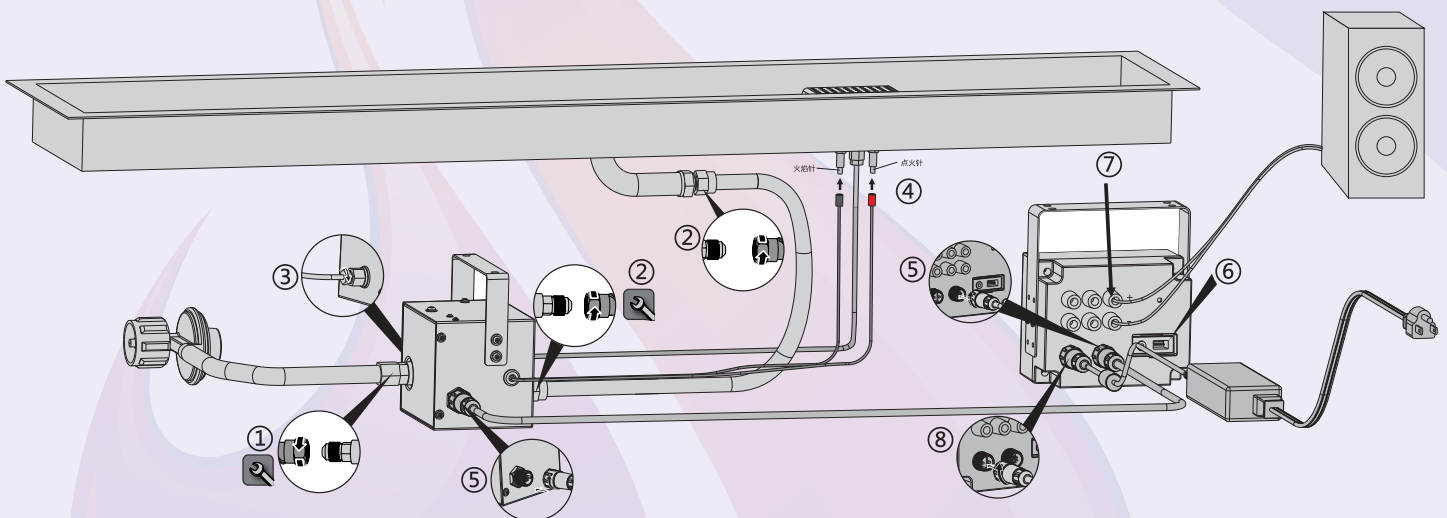

Use liquid soap to check pipes and connections to ensure there are no gas leaks. Professional installers recommended for assembly of the sound reactive fire system.



OPERATION

STEP 2: POWER ON THE SYSTEM

After installation of the Sound Reactive Fire System, press the Music City Fire Company icon button for 2 seconds to power on the system (*fig. 11*). The Music City Fire Company logo will appear in the display (*fig. 12*), followed by the main menu (*fig. 13*).

POWER OFF THE SYSTEM

Press the Music City Fire Company icon button for 2 seconds to power off the system (*fig. 11*).

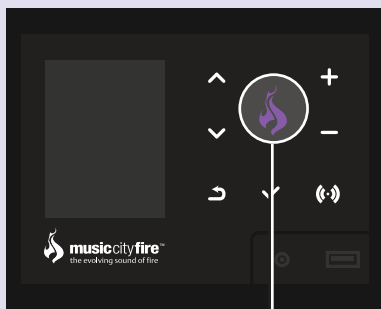

fig. 11

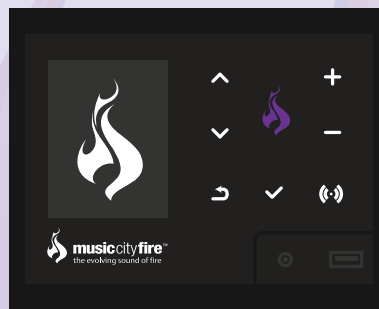

fig. 12

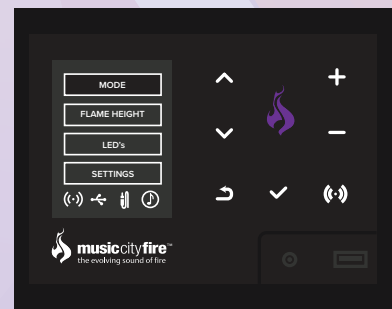

fig. 13

STEP 3: IGNITION AND MODE SELECTION

When the main menu appears in the display, use the up and down arrows to navigate and the check/enter to select each item. Select MODE to choose the operation mode of the unit (*fig. 14*).

Four operation modes are available:

1. REACTIVE - The flame responds to the music being played.
2. FIRE/MUSIC - The flames and music operate separately from each other.
3. MUSIC - Only music will play without fire.
4. FIRE - Only fire will appear without music being played.

Be sure to select each mode by hitting the check/enter. Select the check/enter a second time to ignite the fire. Note under the MUSIC selection, fire will not ignite.

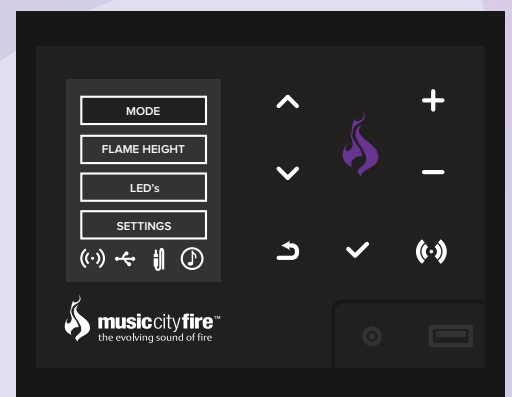

fig. 14

AUDIO

STEP 4.1: AUDIO SOURCE SELECTION

Navigate to and select

1. SETTINGS (fig. 15)
2. AUDIO CONFIG (fig. 16)
3. AUDIO SOURCE (fig. 17)
4. Choose audio source: BLUETOOTH, USB (MP3 format only), AUX-IN, or WIFI (fig. 18)

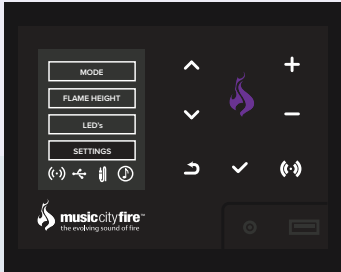

fig. 15

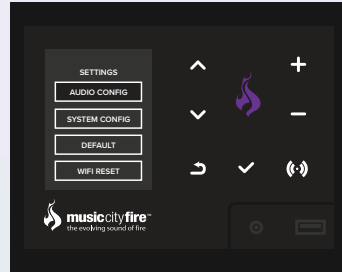

fig. 16

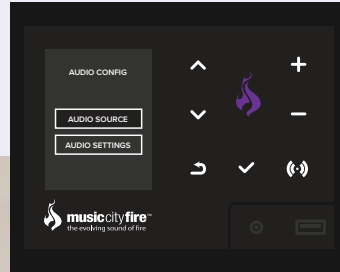

fig. 17

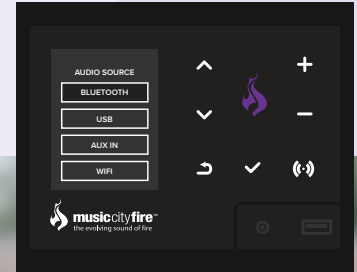
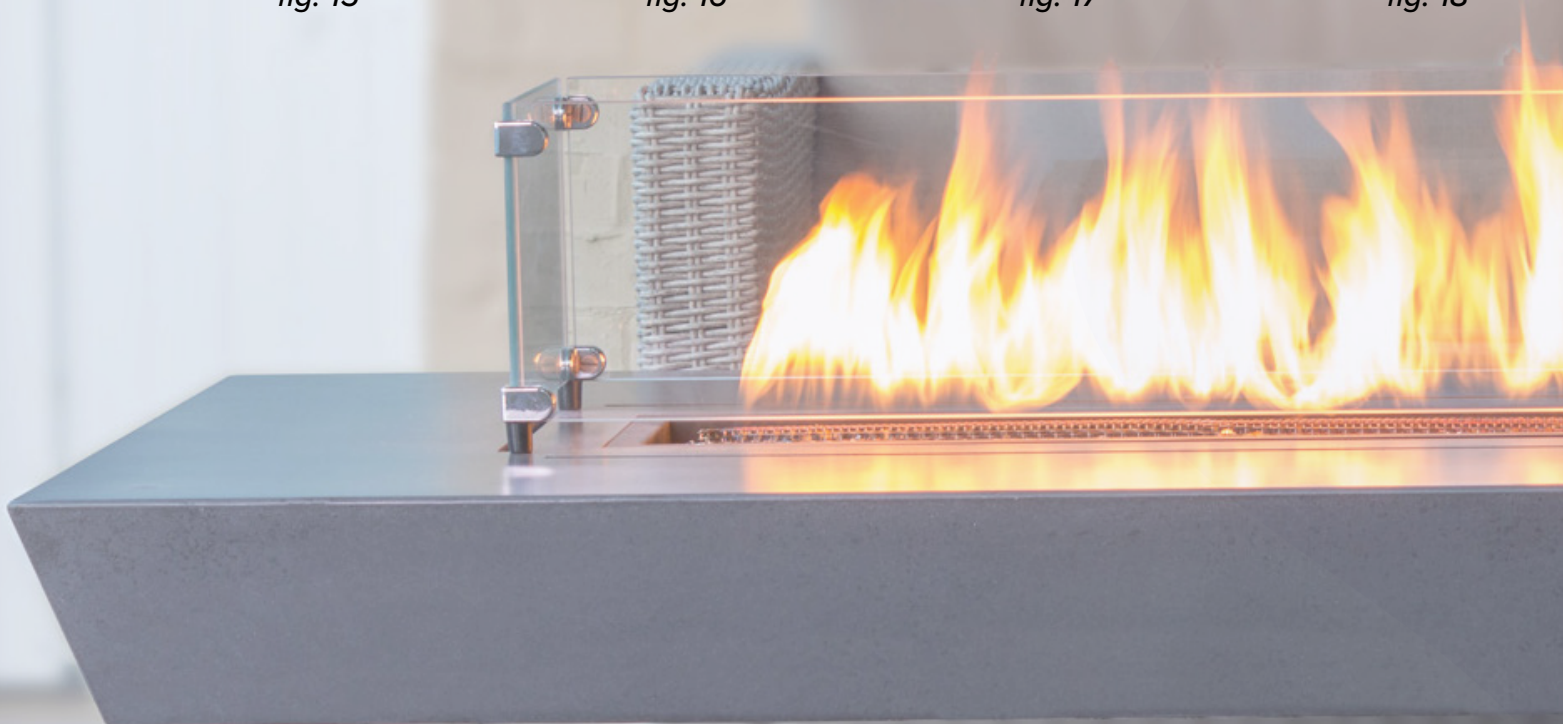

fig. 18



STEP 4.2: AUDIO SETTING

Navigate to and select

1. SETTINGS (fig. 19)
2. AUDIO CONFIG (fig. 20)
3. TREBLE or BASS (fig. 21)

Use volume + or volume - to adjust treble and/or bass

Note the range of treble is -10db -- 0db -- +10db with 2db increments;
the range of bass is -10db -- 0db -- +10db with 2db increments.

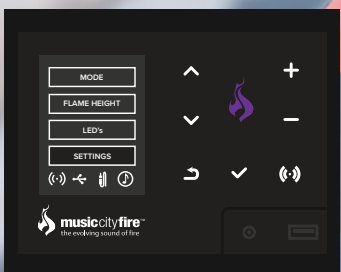

fig. 19

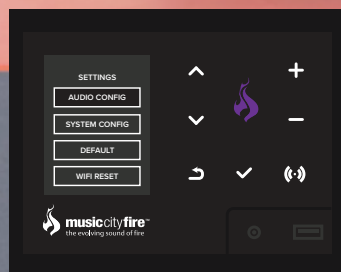

fig. 20

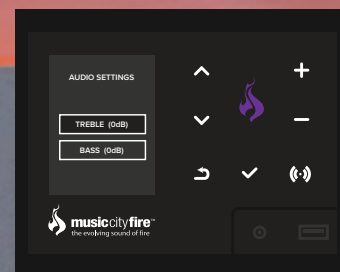

fig. 21

LED

STEP 5.1: LED SETTING

Navigate to and select

1. LED (*fig. 22*)
2. OFF/ON (*fig. 23*)

Use volume + or volume - to switch between OFF and ON.

LED default is set to ON.

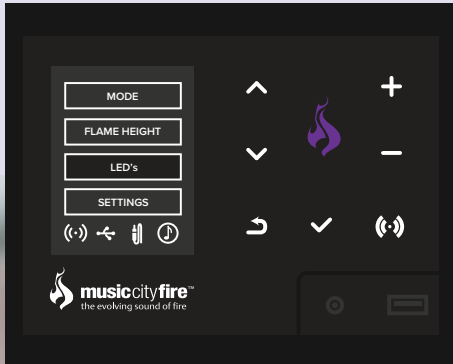

fig. 22

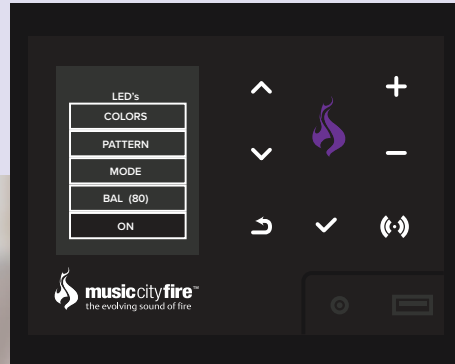

fig. 23

STEP 5.2: LED COLOR SETTING

Navigate to and select

1. LED (*fig. 24*)
2. COLORS (*fig. 25*)

Use volume + or volume - to choose LED color and press enter to select.

The color LED option is only available under the SOLID pattern of the LED display.

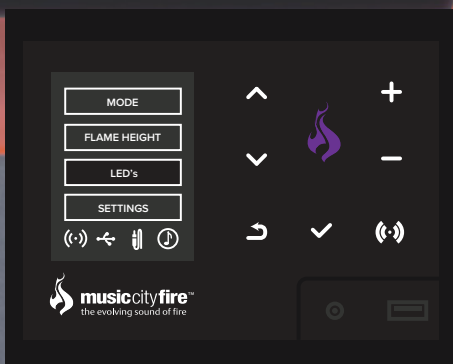

fig. 24

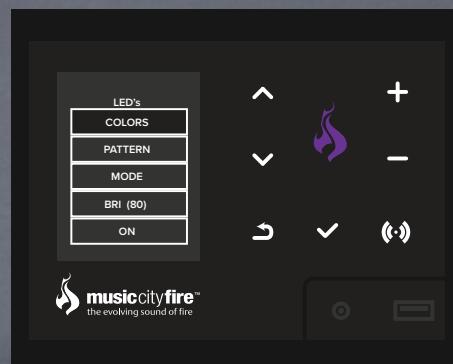

fig. 25

STEP 5.3: LED PATTERN SETTING

Navigate to and select

1. PATTERN (*fig. 26*)
2. Choose from one of the four pattern options available: SOLID, BLINKING, SPECTRUM, BREATHING (*fig. 26*) by using volume + or volume - to choose the desired pattern and press enter to select. LED pattern default is set to SPECTRUM.

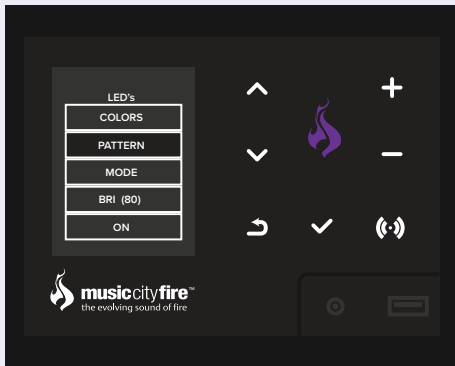

fig. 26

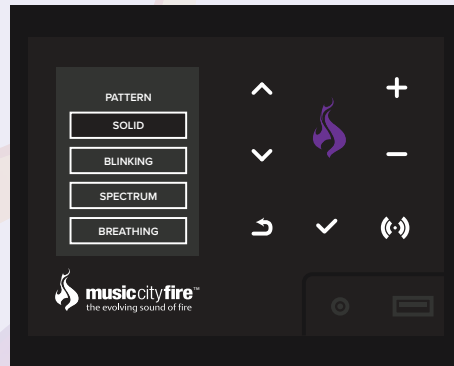

fig. 27

STEP 5.4: LED SOUND REACTIVE MODE

Navigate to and select

1. MODE (*fig. 28*)
2. Select MUSIC to have LEDs react to the music or NON MUSIC to have the LEDs operate independently. (*fig. 29*) Use volume + or volume - to choose the desired mode.

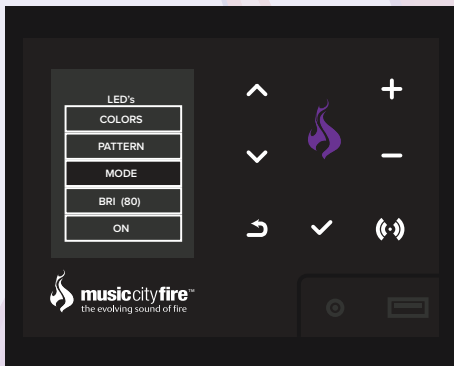

fig. 28

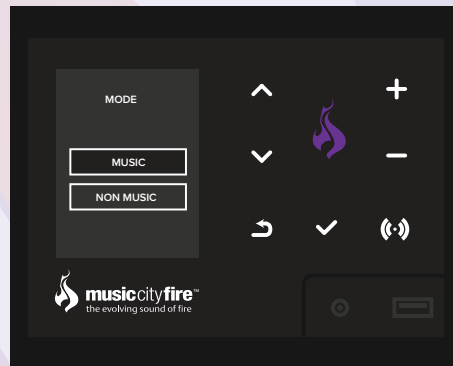

fig. 29

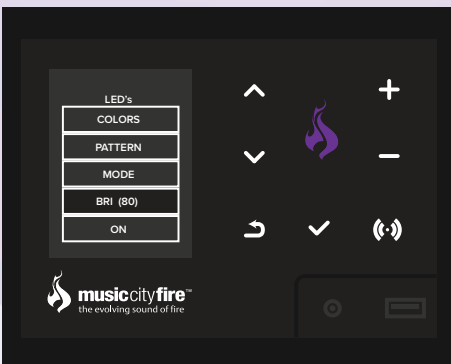

fig. 30

STEP 5.5: LED BRIGHTNESS

Navigate to and select

1. BRI (80) (*fig. 30*)
2. Select MUSIC to have LEDs react to the music or NON MUSIC to have the LEDs operate independently. Use volume + or volume to choose the desired level of brightness.

FLAME

STEP 6.1: FLAME HEIGHT

Return to the Main Menu to manage the flame settings.

1. FLAME HEIGHT (fig. 31)

2. Choose flame height by selecting “1” for minimum, “2” for medium, or “3” for maximum flame height. (fig. 32)

Use volume + or volume - to switch between flame heights and press enter to select.

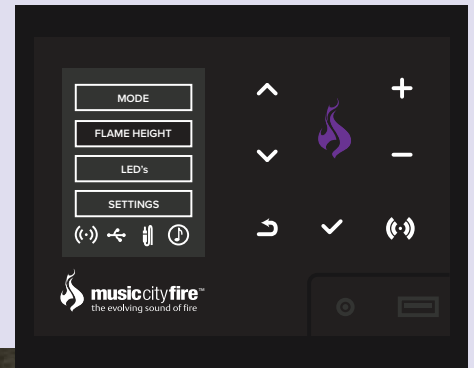

fig. 31

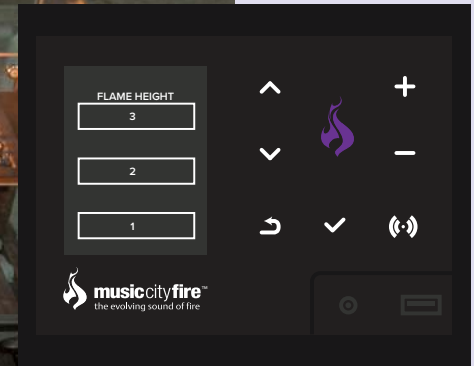

fig. 32

STEP 6.2: MINIMUM FLAME HEIGHT

Return to the Main Menu by selecting the return button or waiting for the screen to refresh after 20 seconds of inactivity.

1. SETTINGS (fig. 33)

2. SYSTEM CONFIG (fig. 34)

3. FIRE CONFIG (fig. 35)

4. MINI FLAME (fig. 36)

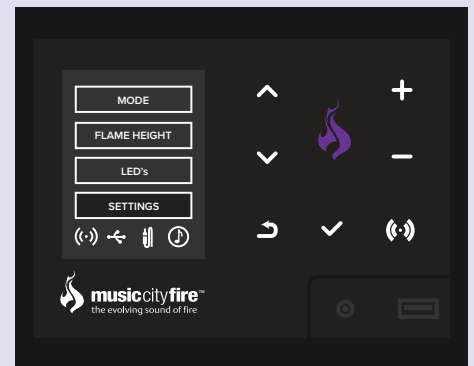

fig. 33

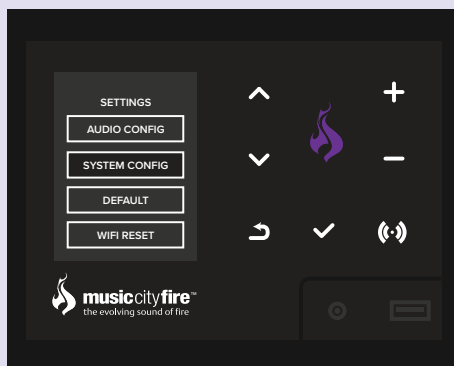

fig. 34

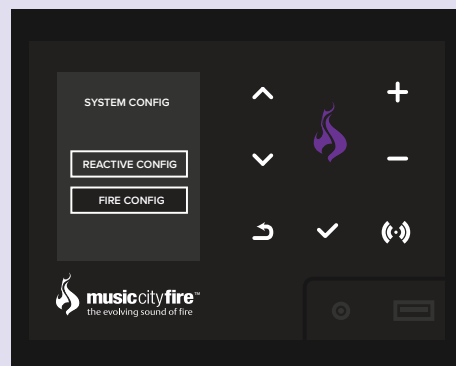

fig. 35

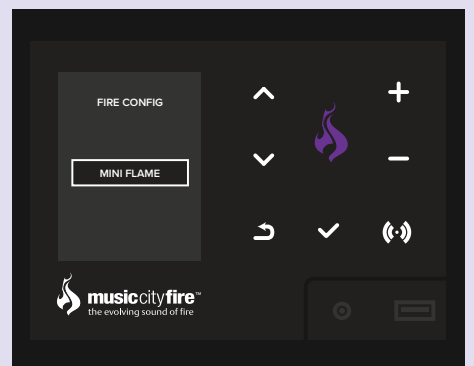

fig. 36



STEP 6.3: REACTIVE FLAME HEIGHT

Set the RESTING Flame Height.

1. Select the SYSTEM CONFIG from (fig. 34)
2. REACTIVE CONFIG (fig. 37)
3. RESTING (fig. 38)

Use volume + or volume - to adjust the resting flame height.

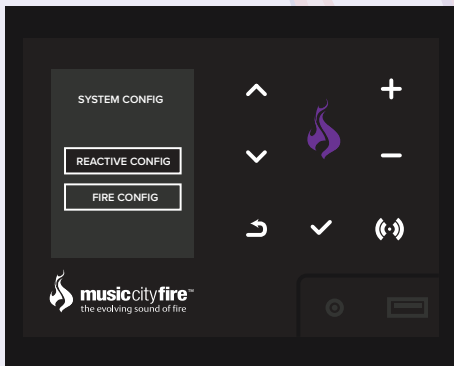

fig. 37

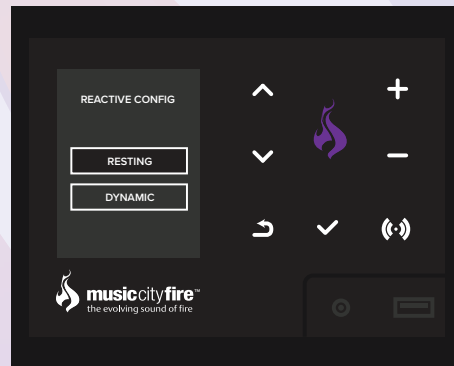

fig. 38

STEP 6.4: DYNAMIC FLAME HEIGHT

Set the RESTING Flame Height.

1. Select the SYSTEM CONFIG from (fig. 34)
2. REACTIVE CONFIG (fig. 37)
3. DYNAMIC (fig. 39)

Use volume + or volume - to adjust the resting flame height.

Note: Music must be paused for DYNAMIC settings. For optimal sound reactive performance, keep the flame about one inch high.

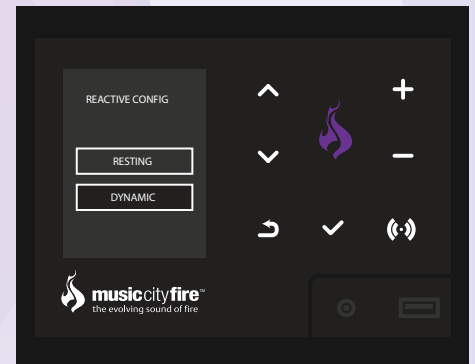

fig. 39

PAIRING

STEP 7.1: BLUETOOTH PAIRING

Navigate to and select

1. SETTINGS (fig. 40)
2. AUDIO CONFIG (fig. 41)
3. AUDIO SOURCE (fig. 42)
4. BLUETOOTH (fig. 43)

Turn Bluetooth on the cell phone and search for the target Bluetooth connect device, “MusicCityFirexxxx.” Click the system icon to confirm connection.

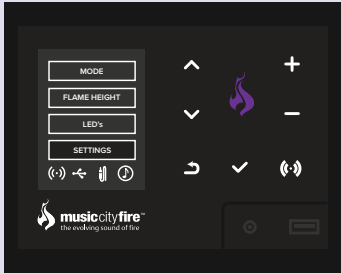

fig. 40

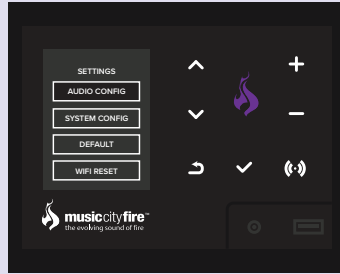

fig. 41

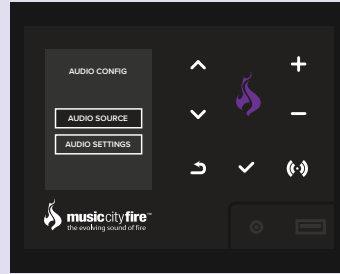

fig. 42

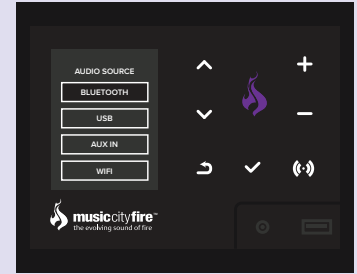

fig. 43

STEP 7.2: REMOTELY CONTROL TWO DEVICES

Two devices can be lines in TWS mode - one works as the LF speaker and the other works for the RL speaker.

Have two devices connect properly with burners, valves, and power supplies.

1. Select BLUETOOTH as AUDIO SOURCE on both devices simultaneously (fig. 40-43)
2. Use a personal device, such as a cell phone, and search for the Bluetooth devices. Twin Bluetooth IDs named “MusicCityFire” will be displayed in the list.
3. Name one of the two devices as “Main.” Press the TWS icon for 5 seconds. The device is set to be “Main.”
4. After 3-6 seconds, only one ID for “MusicCityFire” remains in the list, indicating the TWS setting is complete.
5. Press the “MusicCityFire” ID in the list to pair the device with the cell phone.
6. After pairing, the handheld device or cell phone can play music through the two Bluetooth devices simultaneously.

